



Industrial motor controller for brushed DC motors 24 VDC

Design for output currents up to 6 A

Control with the following functions:

- reversal of direction of rotation
- overcurrent shutdown
- overcurrent indication output
- adjustable current monitoring delay
- short circuit detection
- dynamic brake

To snap onto the DIN rail
EN 50022

Unit width: 17,5 mm

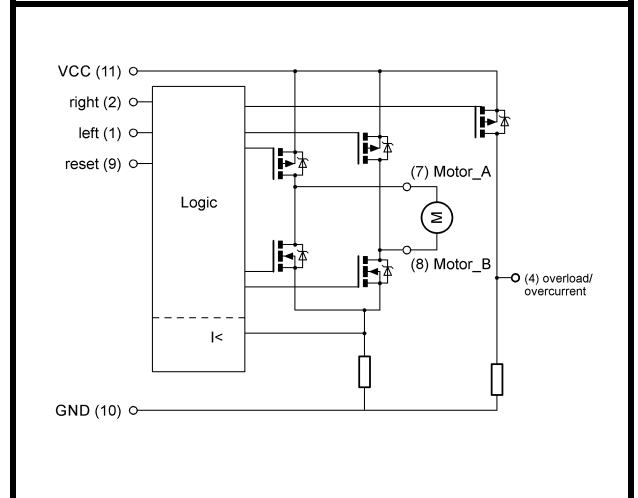

Type	M2-MWI-6-30
Article number	06.34.008
Operating data	
Nominal voltage	U_{nom} 24,0 VDC
Supply voltage	V_{CC} 18 .. 30 VDC
Control inputs	U_{DI} 24,0 VDC
Quiescent current typ	I_0 50 mA
Technical data: load circuit	
Max. current / continuous load current	I_{max}/I_{con} 15 / 6 A
Short circuit current detection typ	I_{SC} 80 A
Shut-down time after short circuit typ	t_{sc} 100 μ s
Power stage driver	MOS-FET
Other data	
Dimensions	17,5 x 70,4 x 85,0 mm
Connectors	screw terminal, pitch 5 mm cross section 0,2 – 2,5 mm ²
Permissible ambient temperature	T_{amb} -20 .. +60 °C
Temperature monitoring / overvoltage protection	yes / yes
Status indication: error / right / left	LED1 red / LED2 green / LED3 green
Current limitation adjustable over DIP	0,5 .. 6 A
Disable Time trimmer TR1 (CM-delay)	0 .. 1 s
Dynamic brake (Armature short circuit)	always on

Other data	
Installation orientation / Assembly	any / top-hat rail EN 50022
Installation place, typical	Switch cabinet
Storage temperature	-30 .. +85 °C
Permissible humidity	0 to 95 %, non-condensing
Weight	0,075 kg
Start up time	2 s
MTBF (SN29500, 40°C, rated load)	94,1 years
Hazardous substance norm	RoHS2
EMC interference immunity	EN 61326-1:2013-01 EN 61000-6-2:2005-08
EMC emitted interference, operation in industrial DC network	EN 61326-1:2013-01, Class A
EMC emitted interference, operation with power supply	EN 61326-1:2013-01, Class B
supply unit / power unit	KDR 120-24, Ott GmbH & Co. KG or comparable

Technical data: digital output overcurrent	
„Ready“	GND (4,7kΩ Pull-Down)
„Overcurrent“	V _{CC}
Current typ	I _{DO} 700 [mA]
Short circuit-proof	Yes, self-limiting

Technical data: digital input	
High Signal typ.	U > 10 V
Low Signal typ.	U < 4 V
Impedance typ.	R _{DI} 15 kΩ

Flammability	
Housing, terminals, printed circuit board	UL94V-0

Starting behavior

After applying supply voltage, the module is ready for operation when the start up time has elapsed.

Description

The module is a two quadrant motor control for use in industrial environments. It ensures the switching on and off, as well as the controlled driving of motors. Over a DIP switch the motor current limit value for the overcurrent shutdown is adjustable. The continuous load current from the module is 6A. A digital output reports if the module is in overcurrent shutdown mode. Current monitoring delay is adjustable over Trimmer TR1.

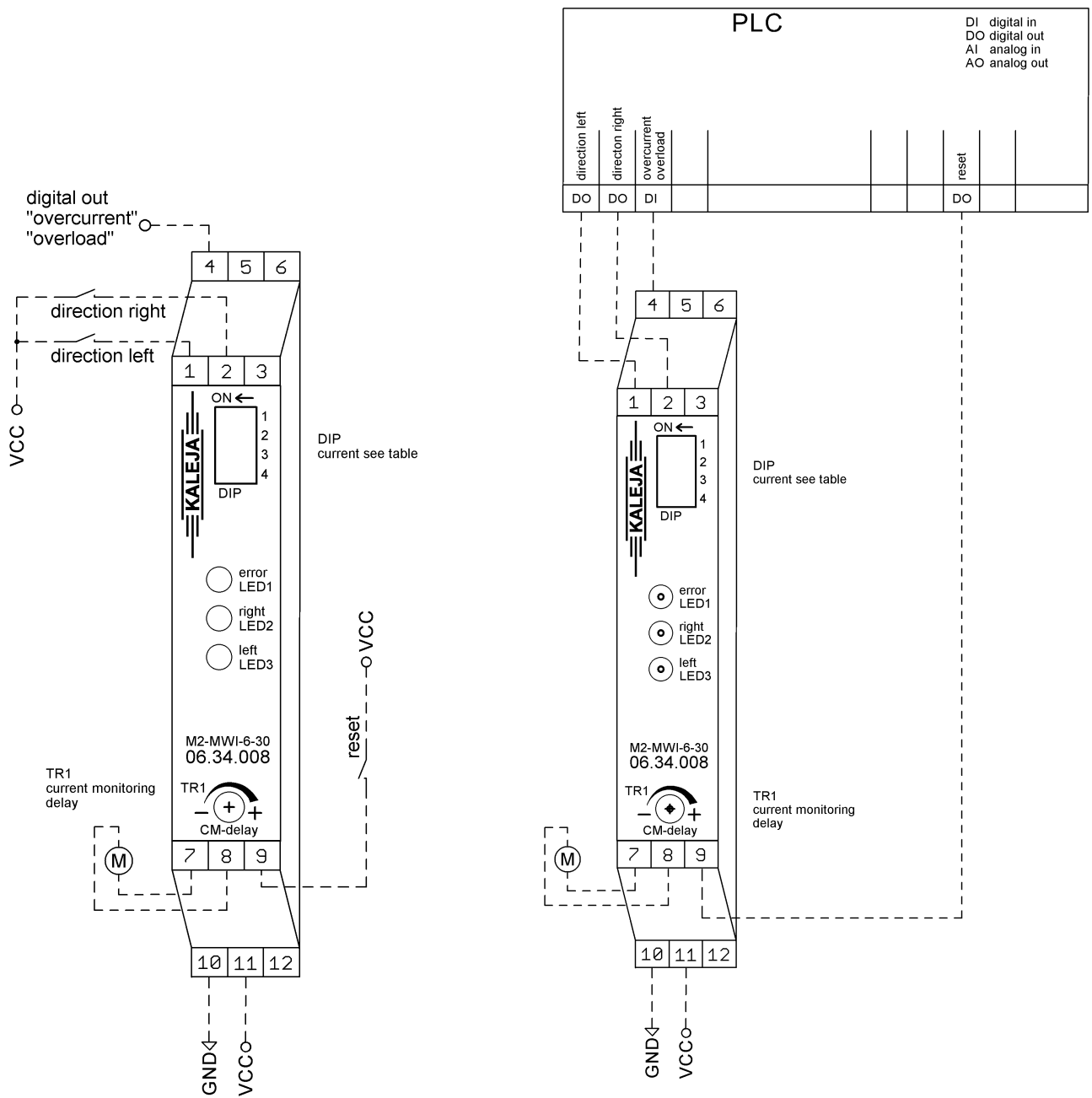

The module has two digital inputs to select the rotation directions and one digital input to reset the module if an overcurrent shutdown has appeared.



Terminal diagram

4 digital output „overcurrent“ High-aktiv	5 Reserved NC	6 Reserved NC
1 digital input „direction left“ (p- switch)	2 digital input „direction right“ (p- switch)	3 Reserved NC
7 Motor winding B	8 Motor winding A	9 digital input „reset“ (p- switch)
10 GND supply	11 +24 V supply +/-10 %	12 Reserved NC

State table

direction „left“ (1)	direction „right“ (2)	Motor „A“ (9)	Motor „B“ (10)	Funktion
0	1	VCC	 GND	run right
1	0	 GND	VCC	run left
1	1	GND	GND	dyn. braking
0	0	GND	GND	dyn. braking

0 = off 1 = on x = don't care

Function: overcurrent shut-off / overload Function: setting the maximum motor current

overcurrent shutdown:

The module has a DIP switch to adjust the current limit.

In case of an overcurrent shut-off the digital output (4) is set HIGH.

To reset the module set a HIGH Signal on digital input "reset" (9) or set both direction inputs(1 & 2) to low and start again in any direction.

overload shutdown:

The module is internally protected with an overload shutdown. In case of rising of the motor current over the rated continuous load current the module switches of with a thermal safety function. After the shutdown the module is locked for a cooldown phase which is managed by the module.

In case of an overcurrent shut-off the digital output (4) is set HIGH.

To reset the module the cooldown phase must be over and both direction inputs (1 & 2) must set to low and start again in any direction.

The maximum motor current is adjusted via the DIP switch on the module.

The maximum permissible motor current is set via the DIP switches 1-4 (see table).

DIP1	DIP2	DIP3	DIP4	Max. current [A]
Off	Off	Off	Off	0,5
On	Off	Off	Off	0,75
Off	On	Off	Off	1
On	On	Off	Off	1,25
Off	Off	On	Off	1,5
On	Off	On	Off	1,75
Off	On	On	Off	2
On	On	On	Off	2,25
Off	Off	Off	On	2,5
On	Off	Off	On	3
Off	On	Off	On	3,5
On	On	Off	On	4
Off	Off	On	On	4,5
On	Off	On	On	5
Off	On	On	On	5,5
On	On	On	On	6

Function: dynamic brake	Function: overload / short circuit detection
--------------------------------	---

The motor always stops with dynamic brake while normal operation.

When the module detects overload or short circuit on the motor output, the motor switches off without dynamic braking. The motor can be restarted by means of a reset (9) or fresh setting of any input of direction of rotation.

Function: disable overcurrent shutdown	Function: current monitoring delay
---	---

The overcurrent shutdown is disabled while on digital input on terminal (9) a HIGH signal applied. The overload shutdown is still active.

The current monitoring delay is adjustable by trimmer TR1. After setting any direction of rotation input the overcurrent shutdown is disabled for the adjusted time.

Device status	Display elements
----------------------	-------------------------

The module status is displayed via the LEDs on the module front plate.

Module errors are displayed as flashing sequences. The end of the sequence is indicated by a pause of 1 second. The number of flashes indicates the error number.

LED1 red	LED2 green	LED2 green	meaning
Off	Off	Off	Module is operational
Off	On	Off	Run right
Off	Off	On	Run left
flashing	Off	On	Module error 1 (see table) Occurred while running left
flashing	On	Off	Module error 1 (see table) Occurred while running right
flashing	flashing	flashing	Internal Error

Module error 1

1	overcurrent
2	Over-temperature
3	short circuit detected
4	overvoltage
5	overload
6	Under-temperature
7	Low supply voltage
8	

Temperature derating	
-----------------------------	--

At 100% duty cycle and aligned modules with 10mm spacing the following diagram is valid.

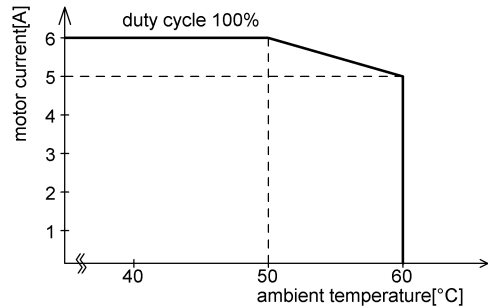

Dimensional drawing

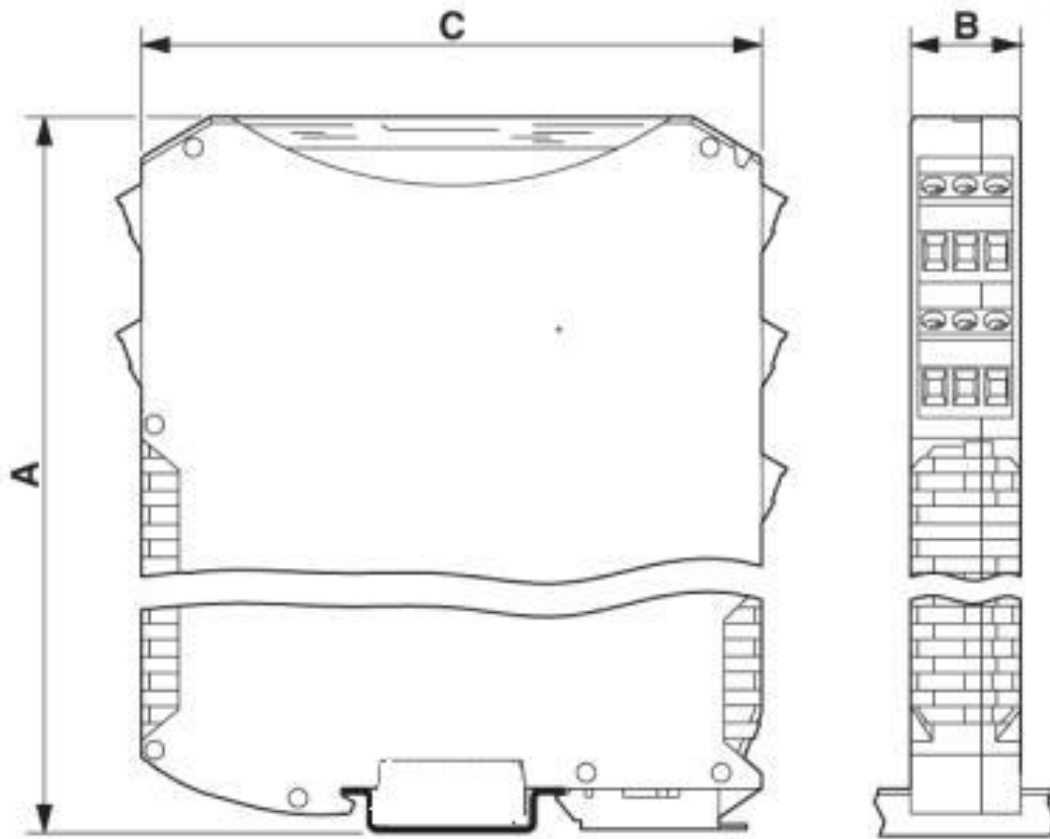

A = 70,4 mm; B = 17,5 mm; C = 85 mm

Safety notes

Maximum operational data

The maximum operating data must not be exceeded.

Installation

The installation and start-up must be performed by specialist personnel exclusively.

All affected components must be disconnected from the mains.

Start-up

For the first start-up, the motor should be operated without load.

Risk of death

Do not touch live parts after switching on!

The assembly must be operated exclusively on safety extra-low voltage. With operation on extra-low voltage (e.g. via autotransformer), death or injury can occur.

Fire protection

The assembly must be installed in a switch cabinet, which is suitable as a fire protection enclosure.

The assembly must be safeguarded with a pre-fuse aligned with the nominal data.

Field of application

The assembly may only be used as intended.

Other components must be checked for their approvals and regulations.

Safety devices

An additional safety device must be used to bring the system into a safe state in case of a cable break, incorrect operation, failure of the control/controller unit.

EMC / EMI

The wiring must be done according to EMC / EMI standards. If necessary, shielded cables and EMC suppressors must be used for the connected consumer.

For operation in a public low-voltage distribution network, the module must be supplied with an approved AC adapter.

If the module is supplied with an AC adapter, other equipment, operated on the same power supply, must be suitable for use in industrial environments.

Repairs

Repairs must be performed by authorised persons exclusively. With unauthorised opening, the warranty cover is voided and this may also result in danger for the user and for the system.

Maintenance

The assembly is wear-free by design.

For modules **with** cooling openings free air circulation must be checked at the cooling openings or on the housing at regular intervals. If necessary, the cooling holes / the housing must be cleaned.

Good ventilation must be ensured.

contact details



ready-to-use motor control solutions
electronics design & manufacturing

KALEJA GmbH

Strübelweg 14

73553 Alfdorf, Germany

Phone: +49 7172 93711 0

Fax: +49 7172 93711 90

E-Mail: info@kaleja.com

www.kaleja.com