



Industrial motor controller for brushed DC motors 24 VDC

Design for output currents up to 5 A

Control with the following functions:

- reversal of direction of rotation
- open-loop speed control (external)
- adjustable start ramp (external)
- overload shut-down
- short circuit detection
- dynamic brake

To snap onto the DIN rail EN 50022

Unit width: 17,5 mm

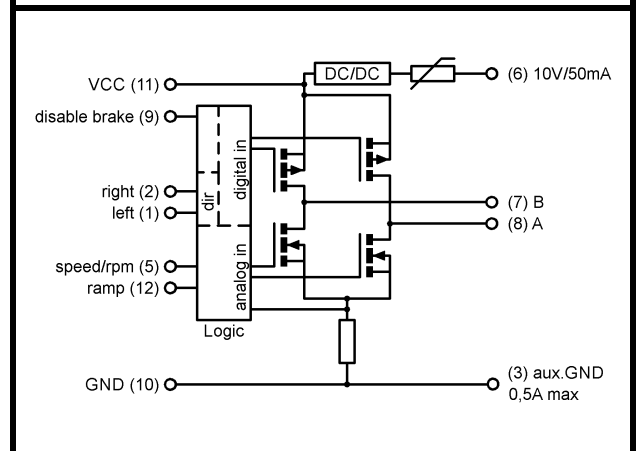

| | |
|-------------|-------------------|
| Type | M2-MR-5-30 |
|-------------|-------------------|

| | |
|-----------------------|------------------|
| Article number | 06.34.001 |
|-----------------------|------------------|

| | |
|-----------------------|--|
| Operating data | |
|-----------------------|--|

| | |
|-----------------------|-----------------------|
| Nominal voltage | U_{nom} 24,0 VDC |
| Supply voltage | V_{CC} 18 .. 30 VDC |
| Control inputs | U_{DI} 24,0 VDC |
| Analog input | U_{AI} 0 .. 10 VDC |
| Quiescent current typ | I_0 50 mA |

| | |
|-------------------------------------|--|
| Technical data: load circuit | |
|-------------------------------------|--|

| | |
|--|----------------------------|
| Max. current / continuous load current typ | I_{max}/I_{con} 15 / 5 A |
| Short circuit current detection typ | I_{SC} 80 A |
| Shut-down time after short circuit typ | t_{sc} 100 μ s |
| PWM frequency | F_s 15,6 kHz |
| Duty cycle | 5 .. 100 % |
| Power stage driver | MOS-FET |

| | |
|-------------------|--|
| Other data | |
|-------------------|--|

| | |
|---|---|
| Dimensions | 17,5 x 70,4 x 85,0 mm |
| Connectors | screw terminal, pitch 5 mm cross section 0,2 – 2,5 mm ² |
| Permissible ambient temperature | T_{amb} -20 .. +50 °C |
| Temperature monitoring / overvoltage protection | yes / yes |
| Status indication: dynamic brake / Left / Right | LED1 yellow / LED2 green / LED3 green |
| Dynamic brake (Armature short circuit) | can be switched off |
| Start ramp | 0,05 .. 4 s |

| Other data | |
|--|--|
| Installation position / Assembly | any / top-hat rail EN 50022 |
| Installation place, typical | Switch cabinet |
| Storage temperature | -30 bis +85 °C |
| Permissible humidity | to 95 %, non-condensing |
| Weight | 0,075 kg |
| Start up delay | 2s |
| MTBF (SN29500, 40°C, rated load) | 123,2 years |
| Hazardous substance norm | RoHS2 |
| EMC interference immunity | EN 61326-1:2013-01 EN 61000-6-2:2005-08 |
| EMC emitted interference, operation in industrial DC network | EN 61326-1:2013-01, Class A |
| EMC emitted interference, operation with power supply | EN 61326-1:2013-01, Class B |
| supply unit / power unit | KDR 120-24, Ott GmbH & Co. KG or comparable |

| Technical data: digital input | |
|-------------------------------|-----------------------|
| High Signal typ | U > 10 V |
| Low Signal typ | U < 4 V |
| Impedance typ | R _{DI} 15 kΩ |

| Technical data: analog input | |
|------------------------------|-------------------------|
| Voltage range | 0 .. 10 V |
| V _{cc} tolerant | yes |
| Impedance typ | R _{AI} 98,5 kΩ |

| Flammability | |
|--|---------|
| Housing, terminal, printed circuit board | UL94V-0 |

Starting behavior

The module M2-MR-5-30 is ready to use after the start up delay. After the module is powered up the startup delay time starts to run.

Description

The module M2-MR-5-30 is a two-quadrant motor control with open loop speed control for DC motors, for use in an industrial environment. It guarantees the switching on and off and the controlled drive of motors. Through two analog inputs it is possible to set the start ramp gradient and the speed of rotation. The motor can be stopped with and without dynamic braking.

Typical application: Standard

Typical application: PLC

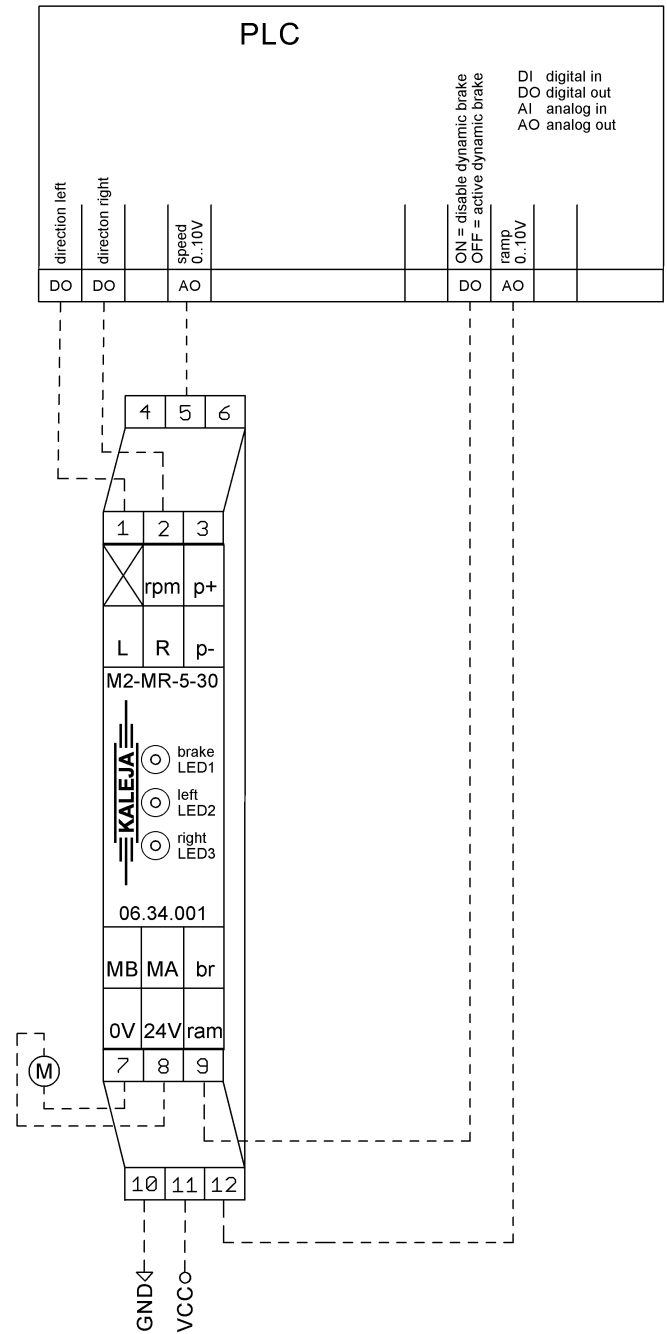
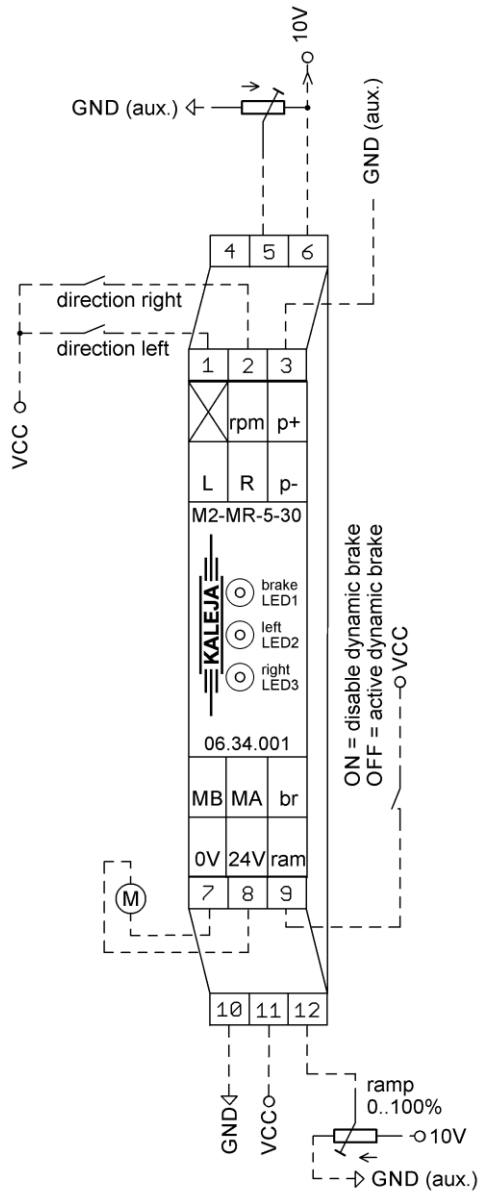

Terminal diagram

| | | |
|---|--|--|
| 4 NC | 5 Analog input 1...10V rotational speed 0..100 % | 6 Auxiliary voltage output +10V/approx. 50mA (PTC fuse) |
| 1 Digital input „run left“ (p- switch) | 2 Digital input „run right“ (p-switch) | 3 GND for external potentiometer |
| 7 Motor winding B | 8 Motor winding A | 9 Digital input „disable dynamic brake“ (p-switch) |
| 10 GND supply | 11 +24V supply voltage, | 12 analog input 0 .. 10V Start ramp 50...4000ms |

State table

| direction „left“ (1) | direction „right“ (2) | disable dyn. braking (9) | Motor „A“ (7) | Motor „B“ (8) | Funktion |
|----------------------|-----------------------|--------------------------|---------------|---------------|--------------|
| 0 | 1 | X | VCC | □□ GND | run right |
| 1 | 0 | X | □□ GND | VCC | run left |
| 1 | 1 | X | GND | GND | dyn. braking |
| 0 | 0 | 0 | GND | GND | dyn. braking |
| 0 | 0 | 1 | open | open | off |

Function: Speed setting **Function: Start ramp**

Via the analog input at terminal (5) it is possible to set the PWM duty cycle that is to be issued to the motor. Within a range from 1 V to 10 V, the voltage is applied as a 0 – 100 % output. With a loading of the motor, the speed reduces.

| voltage (5) | Rotational speed / PWM |
|-------------|------------------------|
| > 10V | 100% |
| 1...10V | Linear 5 – 100% |
| < 1V | off |
| open | off |

Via the analog input at terminal (12) it is possible to set the gradient of the start ramp resp. the time of the start ramp until 100 % PWM is reached. Example: If the speed specification is set to 50 % PWM and the start ramp is set to 4000 ms, the time until 50 % PWM is: 2000 ms.

| voltage (12) | Start ramp time to 100% |
|--------------|-------------------------|
| 0...10V | linear 50...4000ms |
| open | 50ms |

Function: dynamic brake **Function: Overload / short circuit detection**

The function “dynamic braking” is activated as standard. The function is deactivated by applying a High Signal at terminal (9).
If dynamic braking is active, the motor winding is switched to GND at both terminals when switched off. The motor is stopped with armature short circuit braking. If dynamic braking is not active, the motor spins with no braking.

With an overload or short circuit, the motor switches off without dynamic braking. The motor can be restarted by means of a reset and fresh setting of a direction of rotation.

Device status *1 | **Display elements *1**

The module status is displayed via the LEDs on the module front plate.

| LED1 yellow | LED2/LED3 green | meaning |
|----------------|--------------------|---|
| On | Off | Module is ready break is active |
| Off | Off | Module is ready break is deactivated |
| Off | On | Motor is running rotation direction is indicated over LED |
| flashing | On | Module error 1 (see table) |
| flashing | flashing | Internal Error |

Module errors are displayed as flashing sequences. The end of the sequence is indicated by a pause of 1 second.

The number of flashes indicates the error number. LED2/LED3 indicates in which direction of rotation the error occurs. To reset the error the direction Input must be set low and the internal reset conditions must be fulfilled.

Module error 1

| | |
|---|------------------------|
| 1 | overcurrent |
| 2 | Over-temperature |
| 3 | short circuit detected |
| 4 | overvoltage |
| 5 | overload |
| 6 | Under-temperature |
| 7 | Low supply voltage |
| | |

*1 available as of Lot 14/17

Dimensional drawing

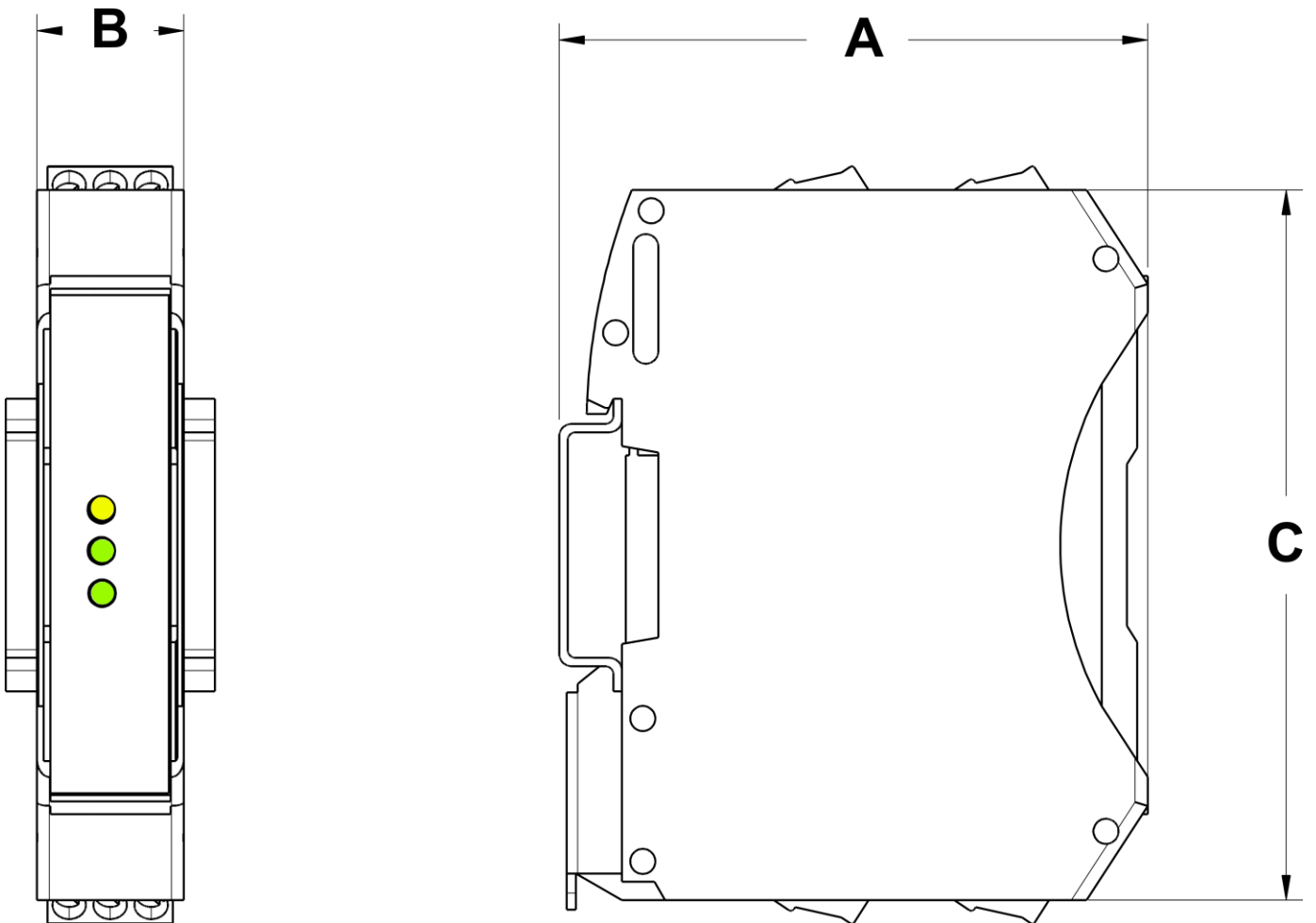

A = 70,4 mm; B = 17,5 mm; C = 85 mm

Safety notes

Maximum operational data

The maximum operating data may not be exceeded.

Installation

The installation and start-up must be performed by specialist personnel exclusively.

All affected components must be disconnected from the mains.

Start-up

For the first start-up, the motor should be operated without load.

Risk of death

Do not touch live parts after switching on!

The assembly must be operated exclusively on safety extra-low voltage. With operation on extra-low voltage (e.g. via autotransformer), death or injury can occur.

Fire protection

The assembly must be installed in a switch cabinet, which is suitable as a fire protection enclosure.

The assembly must be safeguarded with a pre-fuse aligned with the nominal data.

Field of application

The assembly may only be used as intended.

Other components must be checked for their approvals and regulations.

Safety devices

An additional safety device must be used to bring the system into a safe state in case of a cable break, incorrect operation, failure of the control/controller unit.

EMC / EMI

The wiring must be done according to EMC / EMI standards. If necessary, shielded cables and EMC suppressors must be used for the connected consumer.

For operation in a public low-voltage distribution network, the module must be supplied with an approved AC adapter.

If the module is supplied with an AC adapter, other equipment, operated on the same power supply, must be suitable for use in industrial environments.

Repairs

Repairs must be performed by authorised persons exclusively. With unauthorised opening, the warranty cover is voided and this may also result in danger for the user and for the system.

Maintenance

The assembly is wear-free by design.

For modules **with** cooling openings free air circulation must be checked at the cooling openings or on the housing at regular intervals. If necessary, the cooling holes / the housing must be cleaned.

Good ventilation must be ensured.

contact details



ready-to-use motor control solutions
electronics design & manufacturing

KALEJA GmbH

Strübelweg 14

73553 Alfdorf, Germany

Phone: +49 7172 93711 0

Fax: +49 7172 93711 90

E-Mail: info@kaleja.com

www.kaleja.com