

KALEJA Elektronik GmbH
D-73553 Alfdorf

Motor-speed control for brush sticking direct current motor 24VDC.

[à•[|^c^Á|[ä~ &c
& }• ã^! /Ä| E| ECF/ß • c^aa

Implementation for switching current
up to 5A. With speed control,
starting ramp. With change of rotation.

To snap onto DIN - rail EN 50022
and EN 50035.

Construction width: 22,5mm

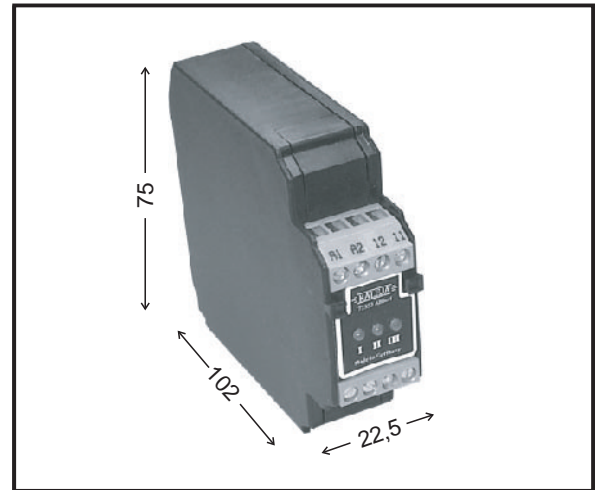

Short designation / type	Rated voltage: 24VDC Maxi-MR-5-30
Art. - No.	06.04.016
Technical data: input circuit	
Rated voltage / threshold voltage	24 VDC
Range of rated voltage min. / max.	19V to 35VDC
Input current during rated voltage	10mA
Analogue input - range of voltage	0V to 10VDC
Status indicator	LED 3mm yellow
Technical data: output circuit	
Range of switching voltage / motor voltage	19V to 35VDC
Max. permanent load current	6A
Current limitation till thermal switch-off come	35A
Speed	0V to VCC adjustable
Starting ramp	50 . 4000ms adjustable
Power driver	MOS-FET
Other data	
ambient temperature range	-20°C to + 50°C
Absence of vibration a/r (10...500Hz)	> 20 / 5
Overload protected / short-circuit-proof / temperature monitoring	yes / yes / yes
DIN VDE-determinations	VDE 0110, 0160 in parts
Position of installation / mounting	can be snapped, addable
Mode of connection: screw terminal	single wire 4mm ² , fine wire 2,5mm ²
Dimensions: W x D x H	22,5mm x 75mm x 102mm

Description

The Maxi-MR-5-30 module is a two-quadrant motor control system for 24VDC motors. It ensures safe switching ON/OFF and the controlled driving and braking of motors. The load can be short-circuited in OFF conditions which result in dynamical braking.

Special features: Short-circuit protection, temperature protection, analog input for speed control and starting ramp.

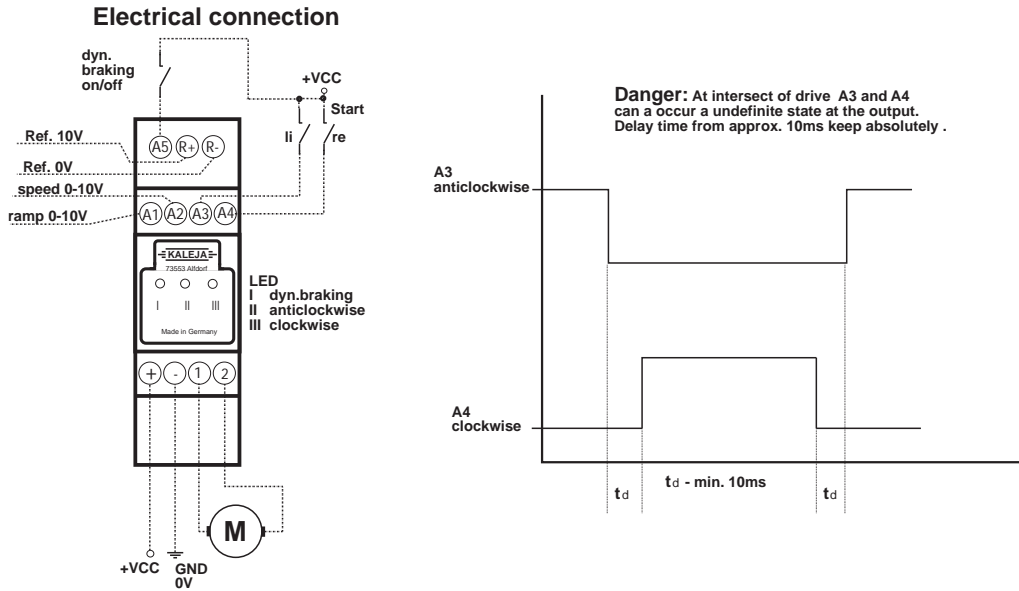

Tab.1 Switching inputs and switching state at the outputs

Inputs			Outputs		
A3	A4	A5	1	2	Dyn. braking
Input/anticlockwise	Input/clockwise	Dyn.braking	Motor connection	Motor connection	
0	0	0	0V	0V	on
0	0	I	0V	0V	off
0	I	X	+VCC	0V	off
I	0	X	0V	+VCC	off

I = +VCC
 0 = 0V
 X = It doesn't matter

Tab2) Input A1 and ramp time

Input A1 Ramp	Ramp time till 100% output voltage be reached
open	50ms
0V	50ms
10V	4000ms

Tab3) Input A2 and motor speed

Input A2 Speed	Output voltage during 12VDC supply.
open	0V
<1V	0V
>1V to 10V	linear from 0V to 12V