

# Operating Manual

## FRU-200

### Digital Frequency Converter

### 0.25 – 0.75 kW

---

#### KALEJA Elektronik GmbH

Strübelweg 14, D-73553 Alfdorf  
Phone. +49 7172-93711-0 Fax +49 7172-93711-90  
<http://www.kaleja.com> e mail: [info@kaleja.com](mailto:info@kaleja.com)

---



This operating manual contains important information on CE marking:  
- Validity  
- Project planning, assembly and wiring, commissioning and servicing

—

© Copyright KALEJA 2009

All rights reserved. Forwarding as well as multiplication of this documentation, utilization and the disclosure of its contents is prohibited unless specific approval was given. Contraventions will incur compensation payments.

The manufacturer reserves the right to correct or alter content and product details as well as omissions without prior notice and does not assume liability for damages, injuries or expenses resulting from aforementioned measures.

**For your retention**

---

# Table of Contents

---

<b>1</b>	<b>GENERAL</b>	<b>3</b>
1.1	RE THIS OPERATING MANUAL	3
1.1.1	<i>Definition of pictographs</i>	3
1.2	TECHNICAL MODIFICATIONS	3
<b>2</b>	<b>SAFETY NOTES AND ENVIRONMENTAL PROTECTION</b>	<b>4</b>
2.1	GENERAL SAFETY INSTRUCTIONS	4
2.2	ENVIRONMENTAL PROTECTION	6
2.3	ADDITIONAL INFORMATION	6
<b>3</b>	<b>DESCRIPTION OF DEVICE</b>	<b>7</b>
<b>4</b>	<b>TECHNICAL DATA</b>	<b>10</b>
4.1.1	<i>General information</i>	10
4.1.2	<i>Electrical data of power section</i>	11
4.1.3	<i>Electrical specifications for control section (Optional – available on request only)</i>	12
4.1.4	<i>Special requirements for installation as per UL requirements</i>	13
4.1.5	<i>Type coding</i>	13
4.2	ORDER DATA	13
<b>5</b>	<b>DESCRIPTION OF FUNCTION</b>	<b>14</b>
<b>6</b>	<b>CONNECTION AND WIRING HINTS</b>	<b>15</b>
6.1	BASIC WIRING DIAGRAM	16
6.2	PIN CONFIGURATION CONTROL SOCKET (FRU-200-25E / 37E / 75E)	17
<b>7</b>	<b>INSTALLATION</b>	<b>18</b>
7.1	PRECAUTIONARY MEASURES FOR ASSEMBLING	18
7.2	MECHANICAL INSTALLATION	18
7.3	DIMENSIONED DRAWING AND ASSEMBLY DIMENSIONS	19
7.3.1	<i>Frequency converter</i>	19
7.4	ELECTRICAL INSTALLATION	20
7.4.1	<i>Power supply wiring</i>	20
7.4.2	<i>Overload and short circuit protection</i>	21
7.4.3	<i>Earthing</i>	21
7.5	EMC-COMPLIANT INSTALLATION	22
7.5.1	<i>Important information about EMC</i>	22
7.5.2	<i>EMC filter for minimising grid-bound faults</i>	22
7.5.3	<i>Admissible line length of motor cable</i>	23
<b>8</b>	<b>SETTINGS AND COMMISSIONING</b>	<b>24</b>
8.1	OPERATOR PANEL	24
8.1.1	<i>Introduction</i>	24
8.1.2	<i>Function keys for settings of the drive</i>	25
8.1.3	<i>Function keys during on-site operation (local mode)</i>	25
8.1.4	<i>Resetting all parameters to default settings</i>	25
8.1.5	<i>Menu structure</i>	26
8.2	SETTING AND INITIAL START-UP	27
8.2.1	<i>Tests to be carried out before initial start-up</i>	27
8.2.2	<i>Drive system safety</i>	27
8.2.3	<i>Preparations for switching on drive</i>	27
8.2.4	<i>Starting the drive</i>	28

---

8.3	PARAMETER LEVEL.....	29
<b>9</b>	<b>OPERATING AND ERROR MESSAGES.....</b>	<b>35</b>
9.1	GENERAL.....	35
9.2	OPERATION MESSAGES.....	35
9.3	SETTING ERROR).....	35
9.4	ERROR MESSAGES.....	36
9.5	FURTHER TROUBLESHOOTING.....	38
<b>10</b>	<b>SERVICE.....</b>	<b>39</b>
10.1	REGULAR MAINTENANCE.....	39
10.2	REPAIR.....	39
10.3	RETURNS.....	39

---

---

# 1 General





## 1.1 Re this operating manual

This operating manual is intended for users possessing the relevant technical knowledge. This operating manual contains a functional description of the FRU-200 frequency converter. **No** description of the machine or system into which the FRU-200 frequency converter(s) are integrated may be deduced from this operating manual.

This operating manual is meant for everyone who is planning to use the FRU-200, that is, everyone who is involved in its assembly, adjustments, commissioning, service or operation.

All persons concerned have to read the whole operating manual carefully before starting installation or operation.

### 1.1.1 Definition of pictographs

 Attention	<ul style="list-style-type: none"><li>• This symbol indicates danger that may result in personal injury.</li></ul>
 Caution	<ul style="list-style-type: none"><li>• This symbol indicates danger that may result in damage to the device or other machine parts.</li></ul>
 Caution	<ul style="list-style-type: none"><li>• This symbol indicates danger in connection with the influence of electrical variables that may result in damage to or impairment of the device or other machine parts.</li></ul>
 Note	<ul style="list-style-type: none"><li>• This symbol introduces advice or additional information.</li></ul>

**Symbols may be used in combination!**

## 1.2 Technical Modifications

The manufacturer reserves the right to make technical alterations without prior notice.

---

## 2 Safety notes and environmental protection

### 2.1 General Safety Instructions

The warnings and risks below are listed in order to allow the user to enjoy maximum benefit and to point out important safety aspects.



**Attention**

- Installation, commissioning or servicing of these drives must be carried out by expert technicians completely familiar with the workings of this equipment and any related machinery. Non-compliance with this regulation may result in injuries and/ or material damage. All work on the devices must be carried out isolated from the power supply.
- Connect the drive motor to a suitable protective-conductor terminal.
- Non-compliance leads to risk of electric shock. All capacitors in the intermediate circuit carry high voltage, even after disconnection.
- Before opening the device, wait for 3 minutes to allow time for discharge. If the required safety precautions are not followed,
- FRU-200 frequency converters may constitute an electrical safety hazard involving danger to life or injury if the required safety precautions are not followed.
- Rotating and moving machine parts also pose a danger to life, risk of injury or material damage.



**Caution**

- These FRU-200 frequency converters have been factory checked before dispatch. Prior to assembly and commissioning, however, please check the devices for possible damages in transit, loose components, packaging material etc.
- Before carrying out high-voltage resistance tests on the wiring, disconnect the FRU-200 frequency converter from the circuit to be tested.

**Replacing a device**



**Attention**

- When replacing the FRU-200 frequency converter it is imperative to correctly install all user-defined parameters determining the proper operation of the drive before restarting the device.
- Disregard of this step may result in danger or risk of injury.


**Installation**



**Attention**

- This product has an IP54 rating. To ensure safe and reliable operation, please comply with any assembly regulations relevant for the respective location.
- Make sure that
  - - mechanically faultless fixings according to recommendations are used
  - - the frequency converter is supplied with sufficient cooling air according to the recommended cooling intervals
  - - cables and connection technology meet recommendations
  - - assembly and commissioning is carried out by expert technicians
  - - specified values are not exceeded


**Implementation risk**



**Attention**

- The integration of the devices into other facilities or systems lies beyond the supplier's or manufacturer's scope of responsibility. This includes applicability, effect, operational safety and other facilities or systems.
- If applicable, the user should consider the relevant aspects of the risk assessment below.


**Servicing, Repairs**



**Attention**

- Servicing must be carried out by trained expert technicians according to manufacturer's instructions (or sent off to the supplier for servicing).
- Repairs carried out by the customer, in particular when non-designated spare parts are used for this purpose may result in danger or risk of injury.
- Repair reports for repairs will only be compiled if the defective device is accompanied by a detailed fault description.

**Risk assessment**




**Attention**

- A drive that is operated under faulty conditions or conditions contrary to the intended use may:
  - - adopt incorrect speed
  - - cause high motor overspeed
  - - cause an incorrect direction of rotation for the motor
  - The motor may be live (unless suitable counter-measures are effective on the system)

**The user has to designate sufficient mechanical covers and/or has to install monitoring and safety systems according to safety regulations.**


**Intended use**



**Attention**

- Speed control of asynchronous squirrel-cage rotors or synchronous motors
- The device must be used exclusively for the use intended and according to its predefined operational data. Any incorrect use may cause a serious hazard or material damage and will result in loss of warranty.


**EMC**



**Caution**

- Please comply with the relevant EMC Regulations. The device as such is equipped with an A EMC of class A.
- The use of earth current monitoring systems in combination with FRU-200 frequency converters or similar is **not suitable for personal protection**. Personal protection will have to be provided in a different way, see EN50178/VDE0160.


**VOLTAGE INTERRUPTIONS**



**Attention**

- The performance of the FRU-200 frequency converter cannot be maintained during a voltage interruption.


**START-UP ON VOLTAGE RETURN**



**Attention**

- Automatic start-up after voltage return is possible for frequency converters FRU-200-25E/37E/75E and FRU-200-25W/37W/75W, provided:
  - - external start is pending for FRU-200-25E/37E/75E
  - - direction of rotation is predefined for FRU-200-25W/37W/75W

**PROTECTIVE INSULATION**



**Caution**

- All bare, touchable metal parts are protected by basic insulation and earth wires (PROTECTION CLASS I).
- The user will be responsible for the appropriate connection of the earth wire!

---

## 2.2 Environmental Protection



**Attention**

- The packaging provided is flammable and may generate toxic gases if disposed of inappropriately.
- Inhalation of gases may result in damage to health.

**Note on disposal**



**Note**

- Dispose of packaging material in an appropriate way.
- Worn out devices or parts there of must be disposed of separately as electronic waste.
- Copper cables and wiring as well as all other recyclable materials must be fed into the material cycle.

## 2.3 Additional information

**Support**



**Note**

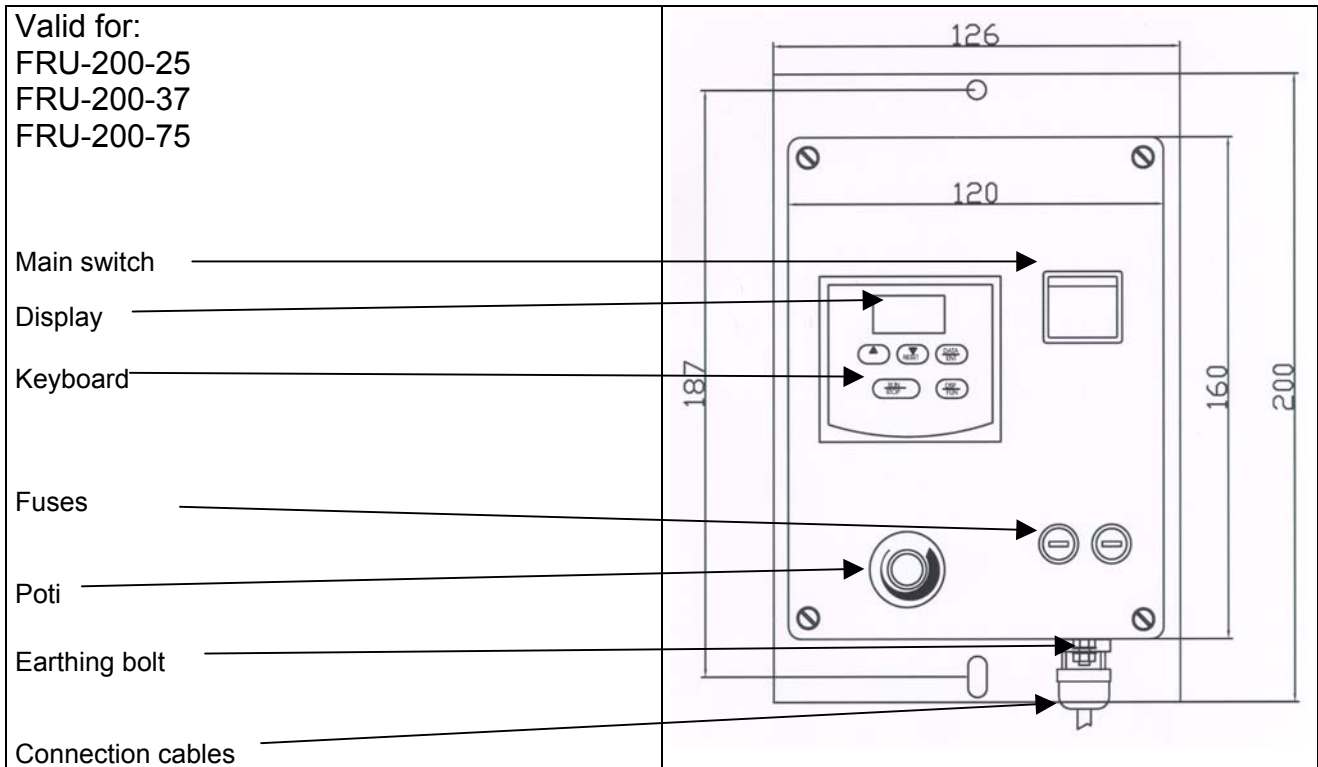
- Please contact your supplier for user support and training.

### 3 Description of device

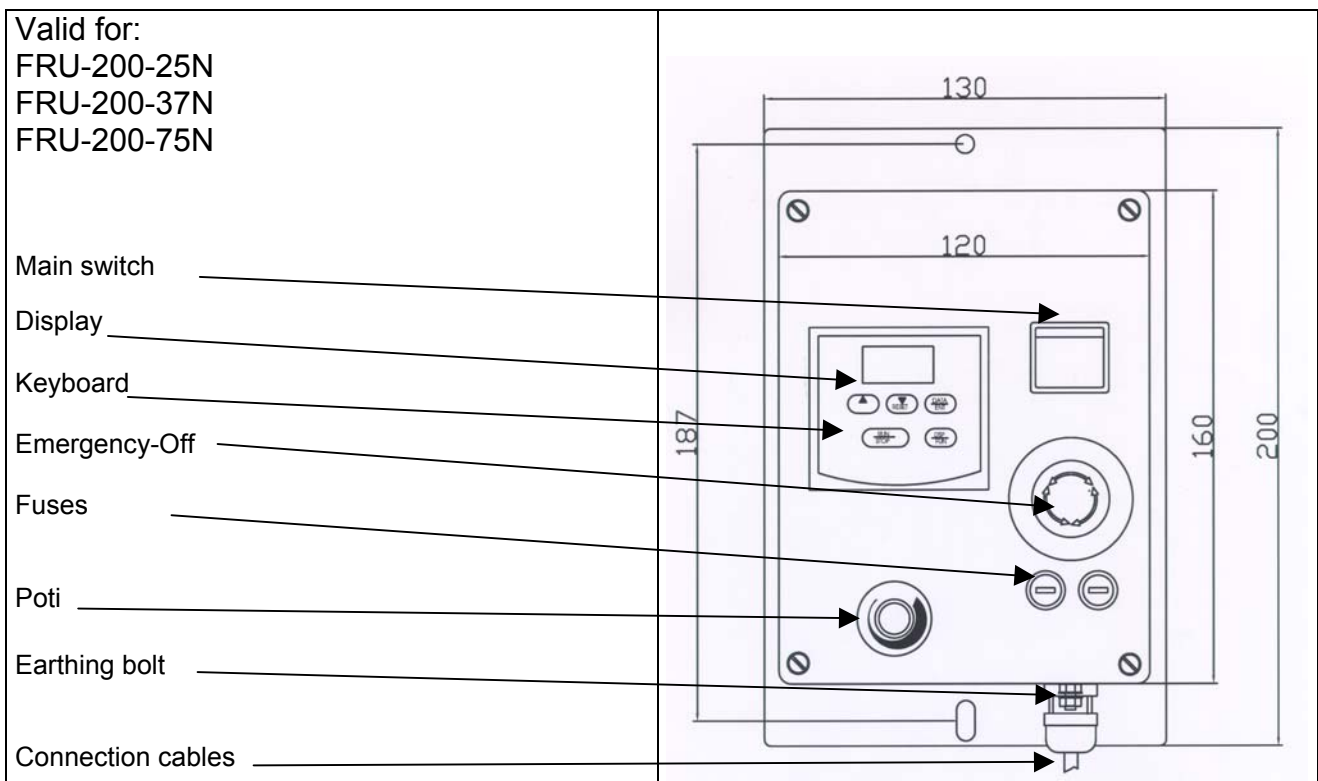
- FRU-200 frequency converter:
- Suitable as driving mechanism for asynchronous motors
  - Universal use in general industrial applications as well as fans and pumps
  - Available for voltage range 1AC 230 V for motors up to 0.75kW
- Modern  $\mu$ P-technology:
- Sinusoidal agitation of motor in entire speed setting range
  - Output frequency from 0 to 200 Hz
  - Clock frequency 4...16 kHz adjustable
- Programming:
- Easy parameterisation and diagnosis providing 3-digit display and 5 function keys enabling on-site control.
  - Extensive integrated protective functions
- Standard packed items:
- FRU-200 frequency converter, mains and motor cable included
  - Operating manual including list of parameters

The most important components depicted on images 1.1a, 1.1b, 1.1c and 1.1d, are explained in the table below.

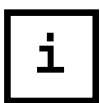
Display:	3-digit display for indication of parameters or values (See chpt. 8.1 control panel)
Operational keys:	These 5 control keys are all you need to define all device parameters. (See chpt. 8.1 control panel)
Main switch:	For turning device on/off
Specified value POT:	For setting the desired value for speed
Fuses:	Micro fuses, quick-acting, for production series FRU-200-25XXX : 4A For production series FRU-200-37XXX : 6.3A for production series FRU-200-75XXX : 10A
Optional: Emergency shutdown switch Control socket: Monitoring switch:	for external activation of frequency converter (FRU-200-25E/37E/75E) Setting the direction of rotation left/right (FRU-200-25W/37W/75W)
Earthing bolt	Additional earthing
Connection cables	Ready-made mains and motor cable



**Fig. 1.1a: Important parts of FRU-200-25 / 37 / 75 frequency converter (standard devices)**

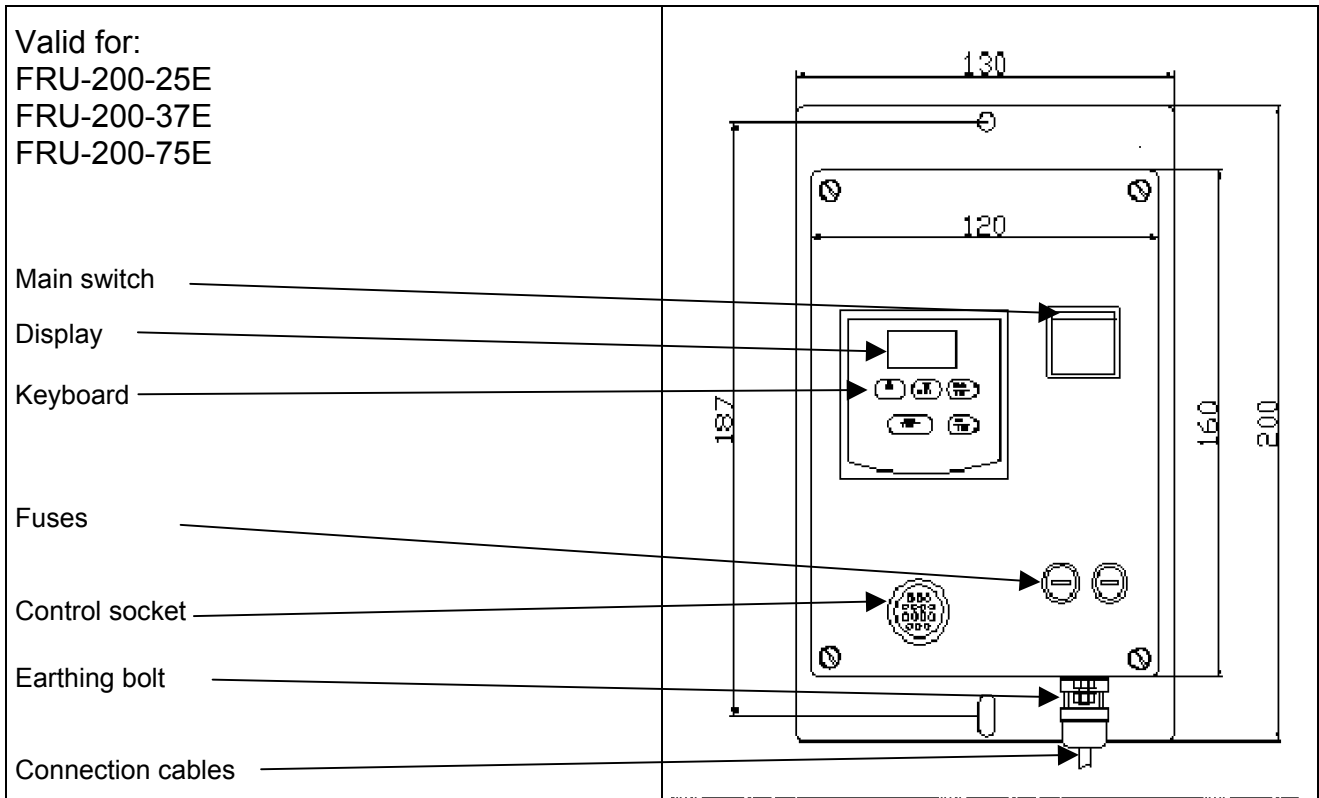


**Fig. 1.1b: Important parts of FRU-200-25N / 37N / 75N frequency converter (devices with emergency shutdown)**

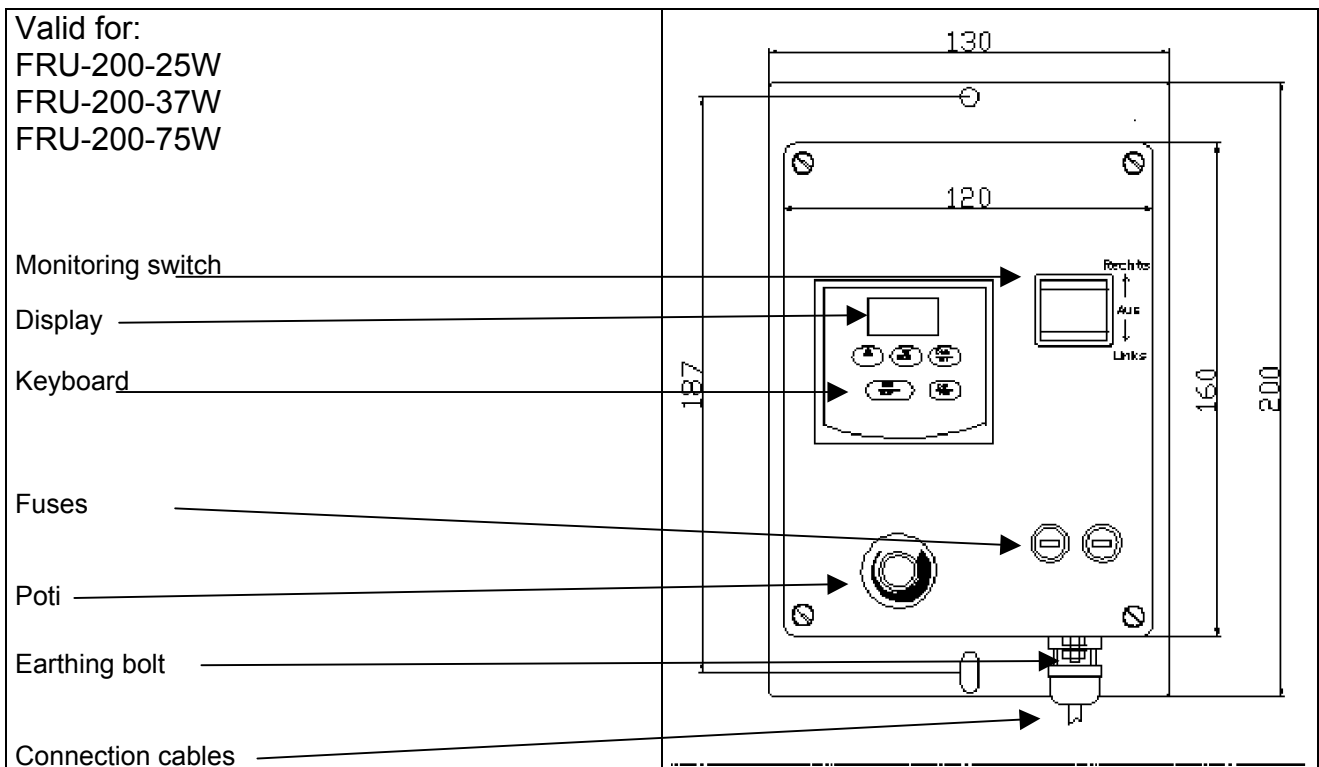


**Note**

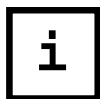
- Apply M4 cable lugs when connecting the earth wire.



**Fig. 1.1c: Important parts of FRU-200-25E / 37E / 75E frequency converter (devices with control socket)**



**Fig. 1.1d: Important parts of FRU-200-25W / 37W / 75W frequency converter (devices with selector switch)**



**Note**

- Apply M4 cable lugs when connecting the earth wire.

## 4 Technical Data

### 4.1.1 General information

Control section:	Operation via integrated control panel or optionally, via external analogue and digital inputs/outputs leading to a socket:	
	Output frequency	0...200 Hz
Boost		0...10 %
Fixed values	specified values	3 (optional)
	Stop functions	Ramp, DC deceleration, coasting
Protections :	Surveillances	Short circuit phase – phase, or phase - earth, peak current 200% rated current, overload 150% 60s, IGBT- overtemperature, overvoltage, undervoltage
	Volts per hertz characteristic	6 different adjustable characteristics
	Overload capacity	150 % I <sub>N</sub> / 60 s
Diagnosis:	Error messages on three-digit LED display	
<b>Optional</b>	<b>FRU-200-25E / 37E / 75E only</b>	via control socket
Inputs/Outputs:	Analogue inputs	Speed specified value 0...+10 V, 0...20mA or 4...20mA
	Analogue output	Output frequency 0...+10 V (0 V = 0 Hz, 10 V = Max. speed (F06))
	Digital inputs	Potential-free contacts or external DC 24 V Industrial logic circuit for: (12/24 V DC): Power up Reverse Multi-function inputs (inching, fixed specified values, emergency stop, external supervision, reset)
	Digital output	Potential-free relay contact for messages: Turned on Specified value has been reached Fault
Voltage:	Voltage	15 % rated voltage for normal application
Frequency 50.		Hz
Overvoltage	category	III
Rated	insulation voltage towards PE	AC 300 V (For use with TT/TN networks with earthed neutral point only)

Environment	Amissible temperatures	Operation: -10 ... +35 °C Storage: -25 ... +55 °C Transport: 0 ... +70 °C short-term
	Climatic conditions	0...95 % relative humidity
	Other	The cooling air used must be as free of dust as possible, non-corrosive and non-flammable
	Installation level	From 1000 m above MSL 1.5 % performance reduction per 100 m; max. 2000 m above MSL
Safety	Applied norms	EN50178
	Protection class	I (IEC 536) basic insulation and earth wire The user will be responsible for a proper connection of the earth wire (PE)
	IP protection type	IP54 (EN 60259)
	Potential separation	Signal and The control circuit is isolated from the mains potential by basic insulation.

#### 4.1.2 Electrical data of power section

Voltage supply:  
Use TT/TN earthed networks only, use with IT networks is prohibited

Normal applications:  
Special applications require prior consultation:

L/N AC 230 V  
50/60 Hz

#### Product Denomination

FRU- 200- 25xxx	FRU- 200- 37xxx	FRU- 200 – 75xxx
-----------------------	-----------------------	------------------------

#### Operation with constant torque

Motor performance	kW	0,25	0,37	0,75		
Motor current I <sub>N</sub> A		1,4	2,3	4,2		
Motor cable	mm <sup>2</sup>	1,0	1,0	1,0		
Connected load	kW	0,53	0,88	1,6		
Line current	A	3,0	5,2	9,4		
Mains fuse / circuit breaker	A	16	16	16		
Power cable	mm <sup>2</sup>	1,5	1,5	1,5		
Earth discharge current	mA	>10	>10	>10		

#### Installation, assembly:

	Cooling system		Conve rter	Conve rter	Convert er		
approx.	weight	kg	2,2	2,2	2,6		
	Dimensions: - Height	mm	200	200	200		
	- Width	mm	130	130	126		
	- Depth	mm	120	120	142		
Cooling	distance	- mm	120	120	120		
	top, bottom						
	at 40°C: - left, right	mm	50	50	50		

### 4.1.3 Electrical specifications for control section (Optional – available on request only)

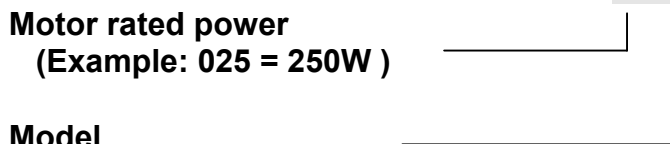
<b>Reference and auxiliary voltages</b>	Reference voltage for analogue inputs	+10 V $\pm$ 5 %, 10 mA max			
	Auxiliary voltages for digital inputs	+12 V $\pm$ 15 %, 50 mA max.			
<b>Analogue inputs/outputs</b>		<b>inputs Output</b>			
	Range	0...+10 V	0...20 mA	4...20 mA	0...+10 V
	Impedance	20 k $\Omega$	250 $\Omega$		
	Max. admissible	10 mA			1 mA
	scanning rate				30 ms
	Resolution				10 bit
<b>Digital inputs and outputs</b>		<b>inputs Output</b>			
	Logic system	DC 12/24 V	Industrial logic circuit		Potential-free relay contact
	Max. load	4.5 mA			250 V AC/1A 30 V DC/1A
	Impedance	3.6 k $\Omega$			
	scanning rate				30 ms
<b>Control terminals</b>	As per EN60204-1, application of 0.2...0.75 mm <sup>2</sup> is recommended.				

## 4.1.4 Special requirements for installation as per UL requirements

- Earth wire connectors:** ♦ Symbol  $\oplus$  (IEC publication 417, symbol 5019) is used to designate the earth wire connector.
- Motor overload protection:** ♦ External motor overload protection has to be provided.
- Overload protection:** ♦ Fuses must be wired inside the supply. Select these fuses according to the **Technical Specifications**, chapter 4.
- Short circuit behaviour of supply:** ♦ Suitable for use in supply with short circuit current not greater than 5000 A rms symmetric
- Corner frequency:** ♦ The maximally adjustable corner frequency is 60 Hz.
- Operating temperature:** ♦ See **Technical Specifications**, chapter 4, for details on ambient and operating temperature.

## 4.1.5 Type coding

FRU-200 ..... **25-x**



**Model**

(0 = Standard)

(N = with emergency shutdown)

(E = with control socket)

(W = with selector switch)

## 4.2 Order data

Function	Product Denomination/ Item number	Technical Data
Frequency converter For operation at 1AC 230V with integrated EMC filter class A	FRU-200-25 (standard)	0.25 kW, 1AC 220-240 V, 1.4 A
	FRU-200-37 (standard)	0.37 kW, 1AC 220-240 V, 2.3 A
	FRU-200-75 (standard)	0.75 kW, 1AC 220-240 V, 4.2 A
	FRU-200-25N (with emergency shutdown)	0.25 kW, 1AC 220-240 V, 1.4 A
	FRU-200-37N (with emergency shutdown)	0.37 kW, 1AC 220-240 V, 2.3 A
	FRU-200-75N (with emergency shutdown)	0.75 kW, 1AC 220-240 V, 4.2 A
	FRU-200-25E (control socket)	0.25 kW, 1AC 220-240 V, 1.4 A
	FRU-200-37E (control socket)	0.37 kW, 1AC 220-240 V, 2.3 A
	FRU-200-75E (control socket)	0.75 kW, 1AC 220-240 V, 4.2 A
	FRU-200-25W (selector switch)	0.25 kW, 1AC 220-240 V, 1.4 A
	FRU-200-37W (selector switch)	0.37 kW, 1AC 220-240 V, 2.3 A
	FRU-200-75W (selector switch)	0.75 kW, 1AC 220-240 V, 4.2 A

## 5 Description of function

FRU-200 frequency converters are micro-processor controlled voltage-source converters, suitable for speed control of three-phase AC squirrel cage motors (norm motors). A hierarchical tree menu with control panel based on a 3-digit LED display provides simple selection of function options as well as setting of parameters.

The basic functions of the FRU-200 frequency converter are described below:

**Power rectifier and intermediate circuit:** The power supply is rectified by means of a non-controllable diode bridge. The DC link is at the rectifier's output, consisting of component parts used to limit the charging current and DC link capacitors. The DC link capacitors smooth the DC voltage that is transferred to the converter power circuit.

**Output converter:** The converter transforms the DC voltage from the DC link into a 3-phase AC voltage used for motor actuation and consists essentially of a driver circuit and IGBT power transistors. Frequency and amplitude are determined by control inputs and the parameters set at the control panel.

**Brakes:** When acting as a generator (brakes), the motor feeds energy back into the intermediate circuit. This elevates the voltage in the intermediate circuit. Minor amounts of braking energy can be absorbed by the intermediate circuit. On reaching the conventional voltage limit (approx. 410V and 800V respectively) the FRU-200 frequency converter under overvoltage will switch off in order to protect integrated component parts.

Most norm motors operated up to the specified speed can be expected to provide considerable braking capacity due to boosted terminal voltage during the braking action (operation with elevated flow).





**Parameter:** Parameters are values or options previously set at the control panel. Normally these parameters have been specified during installation and commissioning and do not require to be adjusted during operation. Parameter such as **Ramp up** (*F01*), determine the travel behaviour of the drive (here boosting acceleration). Parameters such as **Stop Mode** (*P14*), determine the position of a software controlled function key. Control panel functions and those of individual parameters are described in **chapter 4**.

<b>FRU-200-25E / 37E / 75E only!</b>	The selectable analogue input (0...+10 V, 0...20 mA or 4...20 mA) is used to set desired values.
<b>Analogue input and output:</b>	The converter's output frequency can be reduced at the analogue output (0...+10 V).
<b>FRU-200-25E / 37E / 75E only!</b>	As a rule, digital inputs are triggered by external contacts. 0 V and +12 V are available for this purpose. On the other hand it is also possible to switch digital inputs via an external power supply. In this case terminal 10 (OV) acts as reference point.
<b>Digital inputs and outputs:</b>	The digital output uses a potential-free relay contact For detailed information about digital inputs and outputs see pages 2-8.

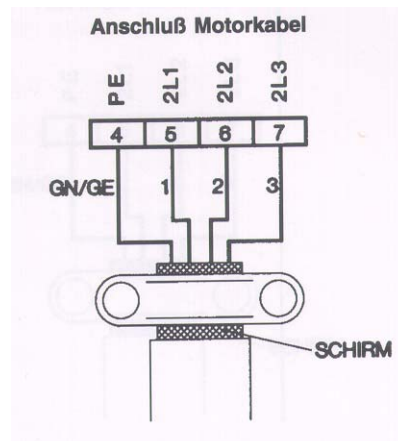
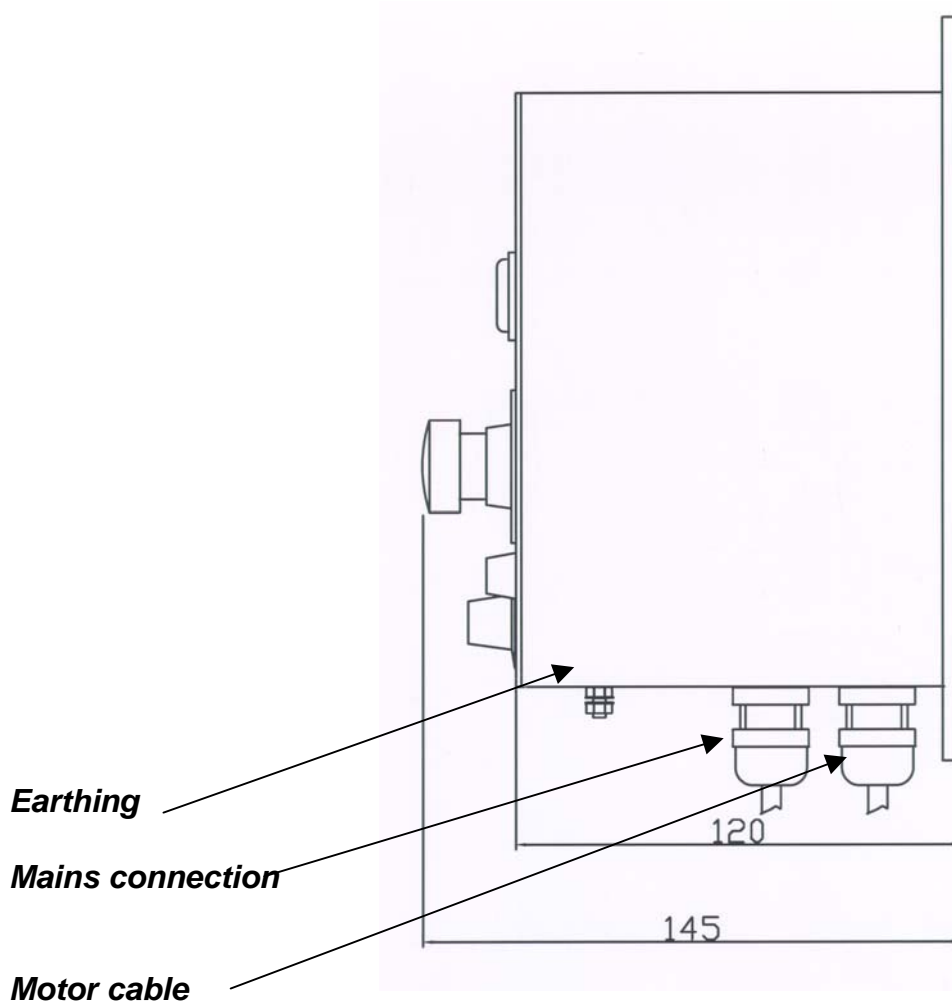
---

## 6 Connection and wiring hints

The images on the next page show a block diagram and a basic circuit. Fig. 2.1 is a basic wiring diagram.

	<b>Attention</b>	<ul style="list-style-type: none"><li>• The device must be connected by trained technical staff.</li><li>• The power terminals carry high voltages. Physical contact may result in <b>life-threatening shock currents</b>.</li><li>• Do not forget to turn off the power supply before carrying out any work on the frequency converter or motor.</li><li>• Wait until the discharge time of the DC link capacitors has passed (no less than 3 minutes).</li><li>• FRU-200 frequency converters are designed for operation in TT/TN networks with earthed neutral point for power supply. <b>The use in IT networks is prohibited.</b></li><li>• Ensure that the additional earthing bolt on the device has been connected.</li><li>• Use only cables with standard connection.</li></ul>
	<b>Caution</b>	
<b>START-UP ON VOLTAGE RETURN</b>		<ul style="list-style-type: none"><li>• Automatic start-up after voltage return is possible for frequency converters FRU-200-25E/37E/75E and FRU-200-25W/37W/75W, provided:<ul style="list-style-type: none"><li>- external start is pending for FRU-200-25E/37E/75E</li><li>- direction of rotation is predefined for FRU-200-25W/37W/75W</li></ul></li></ul>
	<b>Note</b>	<ul style="list-style-type: none"><li>• The basic wiring diagram does not contain comprehensive connection information on EMC and protective earthing (See chapter 7.5 EMC-compliant installation).</li></ul>

## 6.1 Basic wiring diagram



## 6.2 Pin configuration control socket (FRU-200-25E / 37E / 75E)




Con tact	Designa tion	Signal, function	Explication
1 (A) 2 (B)	TRIP RELAY	Digital output (multi-function output): Message turned on; message specified value reached; fault	-potential-free relay contact
3 (C)	FW	Digital input "boost", for starting and shutdown (configurable) of drive +12 V (+24 V) = Boost / forward 0V = Stop Stop	-Shutdown set the same as stop mode (F14) (See pages 4-13)
4 (D)	RE	Configurable digital input, preferably for "reverse" direction of rotation: +12 V (+24 V) = forward / reverse 0V = forward / stop	- FW/RE configurable via operating mode (F03)
5 (E)	+12V	12 V voltage for control inputs	- 50 mA max. load
6 (F) 7 (G)	SP RS	Multi-function inputs: Inching, fixed specified value 1; emergency shutdown; external supervision; reset; fixed specified value 2 +12 V (+24 V) = e. g. inching speed 0V = Standard Operation	- configurable via multi-function inputs (F19/F20)
8 (H)	+10V	Internal +10 V reference for analogue inputs	- 10 mA max. load
9 (I)	Vin	Analogue input for speed specified value: +10 V = max. speed (F06) 0 V = min. speed (F07)	- Enabling of analogue inputs via specified value selection (F11)
10 (K)	0V	Mass for all analogue signals, reference potential for external supervision voltage <b>Warning: See page 16</b>	- Do not use for any other purposes
11 (L)	FM+	Analogue output within range 0...+10 V according to output frequency of the following scaling: +10 V = max. speed (P2) 0 V = 0 Hz	- 10 mA max. load
<div style="display: flex; align-items: flex-start;"> <div style="border: 1px solid black; padding: 5px; margin-right: 10px; text-align: center;"> <b>i</b> Note         </div> <ul style="list-style-type: none"> <li>For information on wire cross-section see chpt. 4.1.3 Electrical Specifications of Control Section on page 12.</li> </ul> </div>			

---

## 7 Installation

### 7.1 Precautionary measures for assembling

When assembling the FRU-200 frequency converter, please take the following precautionary measures:

 <b>Attention</b>	<ul style="list-style-type: none"><li>• Assembly and commissioning of this FRU-200 frequency converters must be carried out by technical staff in compliance with the relevant safety regulations.</li></ul>
 <b>Caution</b>	<ul style="list-style-type: none"><li>• Use reliable fixings by following the recommendations below.</li><li>• Cooling and ventilation correspond to the recommendations made on the dimensioned drawings and assembly dimensions hereinafter.</li><li>• Cable and power terminals must be firmly connected according to recommendations.</li></ul>
 <b>Note</b>	<ul style="list-style-type: none"><li>• For details on minimum distance, fixing and ambient conditions please see chpt. 3.1 Technical Specifications and the drawings below.</li></ul>

### 7.2 Mechanical installation

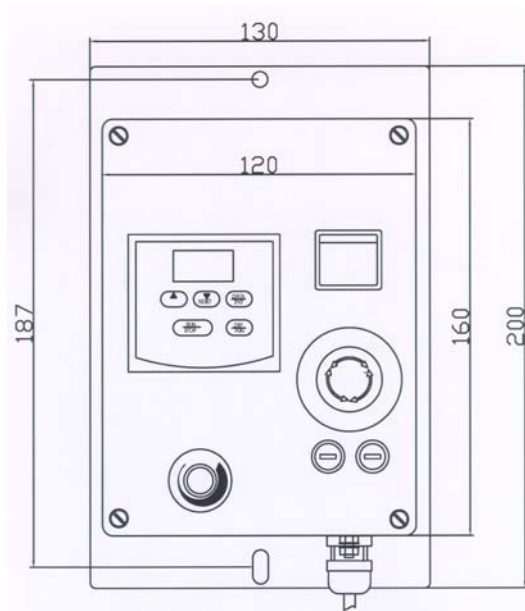
Assemble FRU-200 frequency converters horizontally on a level vertical plane. For dimension of the FRU-200 frequency converter and the position of anchorage points please see fig. 3.1. The following assembly options are provided:

- Assembly on mounting panel using two M6 screws

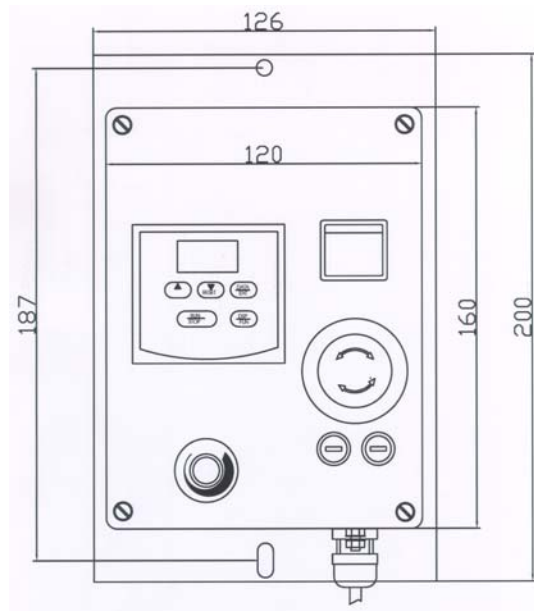
Under normal operating conditions the FRU-200 frequency converter will generate heat. Assembly should therefore allow for unhampered vertical airflow along the converter. In addition, the mounting panel should be cool and any transmission of heat radiating from adjacent equipment should not be transmitted to the FRU-200 frequency converter. To ensure correct ventilation for the FRU-200, arrange for the cooling distance set out in the information on pages 8 and 9. The assembly next to one another of several FRU-200 frequency converters or other devices belonging to the power electronics with simultaneous consideration of the cooling distance is feasible, provided the maximum ambient temperature is not exceeded.

## 7.3 Dimensioned drawing and assembly dimensions

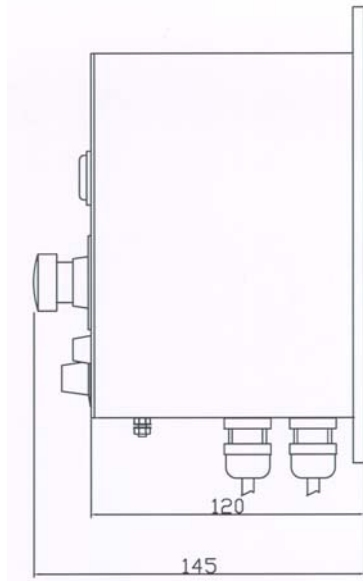
### 7.3.1 Frequency converter



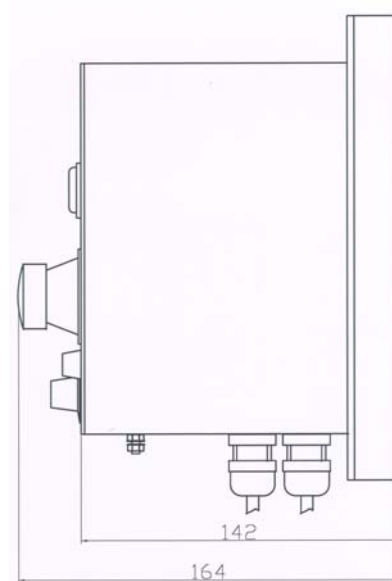
FRU-200-25XXX / FRU-200-37XXX



FRU-200-75XXX



FRU-200-25XXX / FRU-200-37XXX



FRU-200-75XXX

FRU-200	Height	Width	Depth Without switch	Perforation distance A
FRU-200-25XXX / FRU-200-37XXX	200 mm	130 mm	120 mm	187 mm
FRU-200-75XXX	200 mm	126 mm	142 mm	187 mm

**Fig. 3.1: Dimensioned drawing and dimensions**

---

## 7.4 Electrical installation

Wiring requirements for the use of FRU-200 frequency converter for speed alteration will be discussed below. The great variety of specific applications rules out a depiction of all possible wiring diagrams.

### 7.4.1 Power supply wiring



**Attention**



**Caution**

- Please follow safety regulations when working on electrical systems.
- The power terminals carry high voltages. Physical contact may result in **life-threatening shock currents**.
- Comply with all national norms and local safety regulations issued by the local power station.
- Do not forget to turn off the power supply before carrying out any work on the frequency converter or motor.
- Wait until the discharge time of the DC link capacitors has passed (no less than 3 minutes).
- Prior to carrying out high voltage insulation measurements on the wiring, disconnect the FRU-200 frequency converter from the circuit to be tested.

#### Furthermore pay attention to the following:

- Power cables must be designed for at least 1.1 x rated current.
- Lay power cables (in particular 3-phase motor cables) isolated from the desired and actual value cables and from the wiring of other electronic assembly groups.
- What is required is a power supply within the tolerances set out in chpt. 3.1.2 Electrical Specifications Power Circuit, page 8.
- The specified cable cross-sections are as set out in “Electrical Equipment of Machinery“ EN 60204-1, for PVC-insulated copper cables for permanent operation up to 40 °C ambient temperature.
- Allowing for the specified types of layout according to the following differentiation:
  - B1 Protective tube or cable duct with three live single-conductor wires
  - B2 Protective tube or cable duct with three live wires in one cable
  - C Wall mounting of cable with three live wires
  - E Mounting on cable rack

## 7.4.2 Overload and short circuit protection

Carry out and protect supply according to regulations, e. g. see table below:

FRU-200 Type	Power cable			Motor cable	
	Mains fuse <sup>1)</sup> / Power switch <sup>2)</sup>	Cable cross- section	Wiring type	Cable cross- section	Wiring type
FRU-200-25XXX	16 A	1.5 mm <sup>2</sup>	B1,B2,C, E	1.0 mm <sup>2</sup>	B1,B2,C,E
FRU-200-37XXX	16 A	1.5 mm <sup>2</sup>	B1,B2,C, E	1.0 mm <sup>2</sup>	B1,B2,C,E
FRU-200-75XXX	16 A	1.5 mm <sup>2</sup>	B1,B2,C,E	1.0 mm <sup>2</sup>	B1,B2,C,E

<sup>1)</sup> Use standard time-lag fuses <sup>2)</sup> Use power switch with delayed overload behaviour  
(such as protective motor switch)

Different ambient temperatures or customer, national or EMC regulations may require the use of other cable cross-sections. The choice of cable cross-section is the responsibility of the electrician.



Note

- For installations according to UL and other requirements please follow the regulations for installation as per UL.

## 7.4.3 Earthing



Attention

The motor has to be connected to a correctly and permanently installed earth wire. Non-compliance with this direction may result in life-threatening electric shock.

Establish a sufficiently proportioned earth wire connection at the earth terminal by following the relevant regulations.

## 7.5 EMC-compliant installation

The standard version of the FRU-200 series includes an EMC filter of class A. It is also designed for use in the industrial and plant sector . If a higher class is required there is always the option of equipping the device with a filter of class B.



Note

- For further information on the subject matter of EMC please do not hesitate to contact KALEJA Elektronik GmbH. (See chpt. 10 Service)

### 7.5.1 Important information about EMC



Attention



Caution

- The integrated EMC filters inside the FRU-200 frequency converters have been designed for the use in earthed networks. In some installations, however, unearthed networks are to be found. The use of unearthed networks is **prohibited**. Further information is available on request.
- The filters have integrated capacitors between the phases and the phases towards earth as well as discharge resistors. After disconnecting from the mains, please wait for at least 3 minutes before removing the protective covers or touching terminal clamps.  
**Non-compliance may result in life-threatening injuries due to electric shock.**
- **Regulations for safe earthing take priority over EMC earthing at all times.**
- The earth wire connection between the power supply and the FRU-200 frequency converter has to be executed in the form of a fixed installation. For this purpose plan the connection of a second earth wire, parallel to the first, connected to separate earth connections on the FRU-200 frequency converter.
- Each earth wire has to be designed separately according to the rules.
- Clock frequency and cable length to the motor have a considerable effect on the losses of the EMC filter.
- The use of earth current monitoring systems in combination with FRU-200 frequency converters or similar is **not suitable for personal protection** . Personal protection will have to be provided in a different way, see EN50178/VDE0160.
- Please seek information about the relevant directions and possible threshold value changes.

### 7.5.2 EMC filter for minimising grid-bound faults

In order to reduce grid-bound faults, the standard equipment of each FRU-200 frequency converter includes an integrated EMC filter of class A. To reach threshold value B, it is possible to install an additional EMC filter.

The cable connection between the FRU-200 frequency converter and the motor must be installed far from other cables or lines, preferably using a shielded execution.

---

The FRU-200 frequency converter has to be **connected firmly and permanently to the earth wire**, so as to prevent the hazard of electric shock in case of a failure (e.g. phase failure). This is achieved by connecting a second earth wire, connected parallel to the first. Each earth wire has to be designed separately according to the rules.



**Note**

- Anodised or yellow dichromated surfaces such as cable or norm profile rails, screws etc. possess great HD impedance that acts negatively on EMC.
- To ensure protection against corrosion, apply grease to anchoring points and threads.
- Alternatively, you can apply conducting varnish to any empty surfaces on the mounting panel.

**For frequency converter fed drives, cable-bound failures increase proportionately to the length of the motor cable.**

### 7.5.3 Admissible line length of motor cable

Shielded / armoured cables possess a significant capacity between the conductor and the shield. This capacity increases linearly with the cable length. Typical values are 200pF per metre, however, these values depend on the type of cable and the nominal current value. Long cable lengths may exhibit the following undesired characteristics:

- During charging and discharging the cable capacities may, contingent on the switching frequency, tend to faulty shutdowns with “overcurrent”.
- These line-related failures increase with increasing cable lengths, driving the EMC filter to saturation and thereby diminishing the filter effect. To comply with threshold value B (with external EMC filters), cables of a length up to 5m are admissible.
- Triggering earth current control equipment (such as FI circuit breakers) due to increased high-frequency earth currents
- Increased thermal losses in EMC filter

The use of motor throttles at the output of the FRU-200 frequency converter may remedy the problem.

When operating several motors via a single FRU-200 frequency converter, minimise the shielded cable as much as possible. For this purpose, it is best to plan a central allocation point with one cable leading to the FRU-200 frequency converter. For breaks in the shield (such as intermediate terminals, contactors or similar) arrange for a preferably HF-compatible connection for the broken shield.

To achieve an EMC compliant installation without thermal overload of the EMC filter with longer cables than intended you can also use suitable output filters (motor filters). Such motor filters ensure high life expectancy for motors by limiting dU/dt and overvoltage on the motor winding. Install such motor filters as closely as possible to the FRU-200 frequency converter. Ask your supplier for help with selection.

---

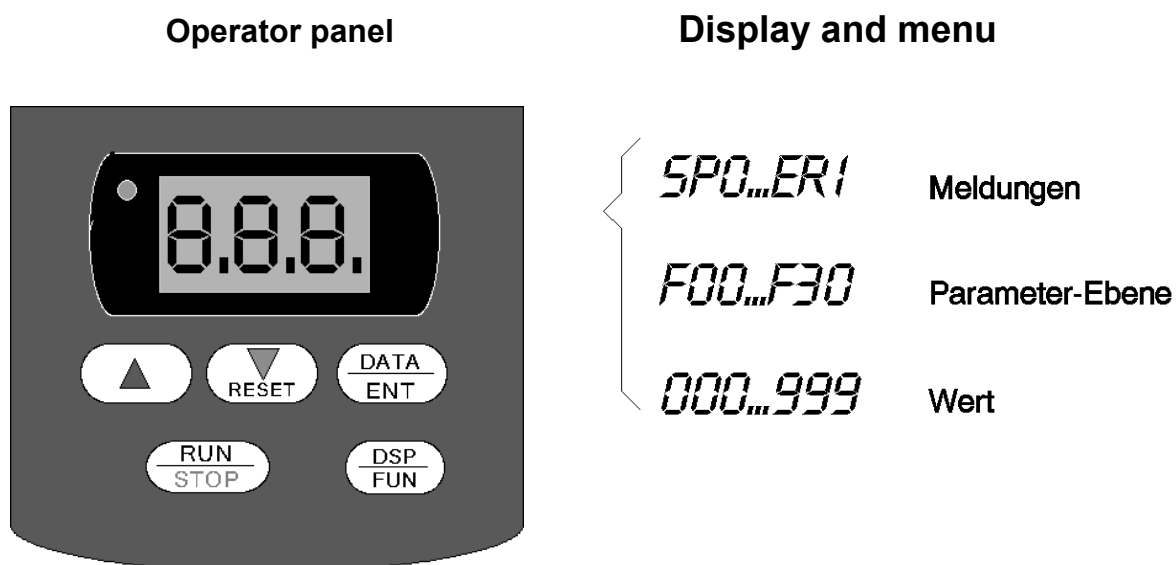
## 8 Settings and commissioning

### 8.1 Operator panel

All settings for the frequency converter are made at the control panel. This function is described below. Users who are already familiar with the control panel can continue with chapter "Settings and initial start-up (page 8.2).

#### 8.1.1 Introduction

FRU-200 frequency converters use a control panel comprising a 3-digit LED display and 5 function keys, see fig. 4.1. This allows simple diagnosis and configuration.



**Fig. 4.1: Operator panel**

## 8.1.2 Function keys for settings of the drive

The 5 function keys enable free movement among the tree menu and the settings for the respective parameters. The individual function of these keys is as follows:



### DSP/FUN

The menu key allows you to switch between the operating mode display and the diagnosis / parameter level. The display shows the specified value in standby mode; output frequency is displayed whilst the motor is rotating. After selecting the parameter level, the most recently selected parameter will appear on the display (F00...F30).



### DATA/ENT

This key is used to access individual values from the parameter level. To return to parameter level, simply press this key again. Any changes you made will be adopted and confirmed beforehand by the message "End".



### HIGHER

This key enables you to advance within the selected menu level. If an adjustable parameter is selected, its value will increase as this function key is pressed.



### LOWER/RESET

This key enables you to return within the selected menu level. If an adjustable parameter is selected, its value will decrease as this function key is pressed. If an error message appears it can be reset by pressing this key.



### RUN/STOP

This key is used to start or stop the frequency converter in local mode.

## 8.1.3 Function keys during on-site operation (local mode)

In local mode, it is possible to control the device on-site and to send start and stop commands via the control panel.

- 1) To change local mode, set parameter F10 to 000.
- 2) Pressing the **RUN/STOP** key initiates the command boost or stop. In the process, you can select between local specified value and remote specified value by using parameter F11.
- 3) The **DSP/FUN** key is used to switch between parameter level and diagnosis level. The diagnosis level indicates the specified value during standby mode. Output frequency will be shown after the start command was given.

## 8.1.4 Resetting all parameters to default settings

This function is used to reset all setting parameters of the FRU-200 frequency converter to factory default settings.



### Caution

All previously set values will be lost. Prior to a restart be mindful of any safety notes on commissioning.

- 1) To reset parameters to default settings, invoke parameter F25.
- 2) For a 50 Hz system this parameter has to be set to 010. For a 60 Hz system this parameter has to be set to 020. Any other settings will have no effect. This function is also used to change the corner frequency from 50Hz to 60Hz or vice versa.
- 3) The parameter F25 will automatically be reset to 000 after invocation. The default settings will remain until the change of individual parameters.

## 8.1.5 Menu structure



### List of parameters FRU-200

(Space available for you to enter your settings)



Parameter	Significance Default	setting	Customer setting	Page
<b>F00</b>	Factory adjustment	000		29
<b>F01</b>	Ramp up	05.0		29
<b>F02</b>	Ramp down	05.0		29
<b>F03</b>	Operating mode	000		29
<b>F04</b>	Direction of rotation	000		29
<b>F05</b>	Volts per Hertz characteristic	001/004		29
<b>F06</b>	Max. speed	50.0/60.0		29
<b>F07</b>	Min. speed	00.0		29
<b>F08</b>	Fixed target value 1	10.0		30
<b>F09</b>	Inching-nominal value	06.0		30
<b>F10</b>	Enable local/remote for <b>FRU-200-25W / 37W / 75W</b>	000 001	30	
<b>F11</b>	Specified value selection local/remote for <b>FRU-200-25E / 37E / 75E</b>	001 000	30	
<b>F12</b>	Clock frequency	005		30
<b>F13</b>	Voltage elevation/boost	00.0		31
<b>F14</b>	Stop mode	000		31
<b>F15</b>	Braking time	00.5		31
<b>F16</b>	Start frequency braking	01.5		31
<b>F17</b>	Braking voltage	08.0		31
<b>F18</b>	Motor rated current	100		31
<b>F19</b>	Multi-function input 1	002		32
<b>F20</b>	Multi-function input 2	005		32
<b>F21</b>	Multi-function output	003		32
<b>F22</b>	Change of direction	000		32
<b>F23</b>	Automatic restart	001		32
<b>F24</b>	Number of restarting attempts	000		33
<b>F25</b>	Default setting	33		
<b>F26</b>	Fixed speed 2	20.0		33
<b>F27</b>	Fixed speed 3	30.0		33
<b>F28</b>	Auto-Start 001			33
<b>F29</b>	CPU program version			34
<b>F30</b>	Error messages	34		

## 8.2 Setting and initial start-up

 <b>Attention</b>	<ul style="list-style-type: none"><li>• Commissioning must be carried out by competent staff.</li><li>• Ensure that no person or object is present within the danger zone.</li><li>• Work on the drive system or merely opening the housing is only permitted under the following conditions:<ul style="list-style-type: none"><li>- Complete disconnection from mains and control-generated power supply</li><li>- Awaiting end of discharge time for intermediate circuit (at least 3 min)</li><li>- Verification that all terminals are isolated from supply</li></ul></li></ul>
 <b>Caution</b>	<ul style="list-style-type: none"><li>• Non-compliance may result in life-threatening bodily harm!</li><li>• Prior to checking whether the motor or the wiring is isolated and prior to checking cable joints, it is absolutely necessary to disconnect the FRU-200 frequency converter from the part to be checked.</li></ul>

### 8.2.1 Tests to be carried out before initial start-up

Please check the following before proceeding with turning on the power supply for the first time:


- 1) Power supply is available as required.
- 2) The motor nominal voltage matches the power supply and the motor is correctly wired and connected in star or star delta.
- 3) The external wiring such as power terminals, motor terminals and above all the safety earthing have been expertly executed.
- 4) There is no visible damage to the FRU-200 frequency converter or the wiring.
- 6) Motor shaft and, as far as available, separate ventilators can be rotated by hand without difficulty.

### 8.2.2 Drive system safety

Check the whole drive system for safety. In particular ensure that

- 1) - machine rotation, regardless in which direction, does not cause damage;
- 2) - no one is working on the machine or drive who may be endangered by switching on the power supply or by movements of the drive;
- 4) - no damage is caused to other facilities or parts by switching on the power supply or movements of the drive.

### 8.2.3 Preparations for switching on drive

<b>Automatic Start-up</b>  <b>Caution</b> <b>Attention</b>	<ul style="list-style-type: none"><li>• Automatic start-up after voltage return is possible for frequency converters FRU-200-25E/37E/75E and FRU-200-25W/37W/75W, provided:<ul style="list-style-type: none"><li>- external start is pending for FRU-200-25E/37E/75E</li><li>- Direction of rotation is pre-selected for FRU-25W / 37W / 75W</li></ul></li></ul>
--	--

Prepare switching on of drive as follows:

- 1) Release FRU-200 frequency converter by removing the input safeguard or opening the circuit breaker.
- 2) If possible, uncouple motor shaft from its load.
- 3) Check whether the power switch or selector switch is set to OFF.
- 4) After 1) ... 3) have been carried out carefully; establish power supply to FRU-200 frequency converter.

- 
- 5) Ensure that important parameters such as POTs are set to minimum end stop (left end stop) and that ramp times are set according to default values (See pages 4-6). These values are suitable for most applications. Application-specific modification may be necessary.
  - 6) Afterwards switch off the FRU-200 frequency converter.

## 8.2.4 Starting the drive

After all these preparatory steps have been carried out carefully and all safety regulations taken into consideration you can then start up the drive as follows:


- 1) Reconnect the power supply. The 3-digit LED display will show a value based on the specified value on the POT.
- 2) If need be, carry out any required additional changes to the parameters at this point (See paragraph "Parameter level"). The mode of action for the function keys is described in chapter.8.1.2 "Function keys for settings of the drive".
- 5) Press the Start key and set a low desired value for speed at the POT. This should result in the motor starting to rotate slowly. For FRU-200-25W/37W/75W it is possible to change the direction of rotation by actuating the selector key. Position on top correlates to direction of rotation to the right, position at bottom correlates to direction of rotation to the left, position in the centre correlates to OFF.
- 4) If the motor rotates in the wrong direction, 2 of the 3 phases may be mixed up. If this is the case, check wiring as described in chpt. 5 Connection and Wiring Information. There is also a chance that the setting for parameter F04 is wrong and has to be changed.
- 5) For applications with a high breakaway torque you can increase the voltage in the lower characteristic curve. To achieve this, increase the value of the related parameter Boost Voltage Elevation (F13), page 31. If the set boost is too high, the frequency converter may report a fault sending error message Overload (oL). You can reset this message by pressing Reset. To avoid this error, either scale back the boost slightly or reduce the starting torque. In an extreme case it will become necessary to fit a converter that provides a higher capacity.
- 6) When several motors are supplied by one frequency converter in parallel configuration each individual motor should be protected against thermal overload by a protective motor switch.




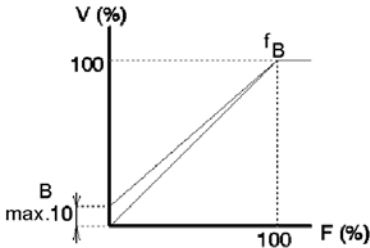


**Caution**




The drive may start overheating during low speed if its ventilation becomes insufficient. In this case, it will be necessary to use a separate ventilator. This usually happens with minor excitation frequencies of <15Hz.




## 8.3 Parameter level


Parameter	Function [default setting]	Settings Grey values are feasible on request!						
<b>F00</b>	Factory adjustment	<b>Do not change this value under any circumstances!</b>						
<b>Ramps</b>								
<b>F01</b>	Ramp up [5.0]	These are used to set the time that is required by the motor to reach the maximum speed specified in parameter F07. Setting range available from <b>[0.1]</b> s to <b>[999]</b> s. Changes may also be made during operation.						
<b>F02</b>	Ramp down [5.0]	This is where you set the time required by the motor from the point of shutdown to a total stop. Setting range available from <b>[0.1]</b> s to <b>[999]</b> s. Changes may also be made during operation.						
<b>Operating mode</b>								
<b>F03</b>	Operating mode [000]	<table style="width: 100%; border: none;"> <tr> <td style="text-align: center;"><b>contact 3</b></td> <td style="text-align: center;"><b>contact 4</b></td> </tr> <tr> <td><b>[000]</b> Forward/Stop;</td> <td>Back/Stop</td> </tr> <tr> <td><b>[001]</b> Boost/Stop:</td> <td>Forward/Back</td> </tr> </table> (See also chpt. 5.3.2 control terminals)	<b>contact 3</b>	<b>contact 4</b>	<b>[000]</b> Forward/Stop;	Back/Stop	<b>[001]</b> Boost/Stop:	Forward/Back
<b>contact 3</b>	<b>contact 4</b>							
<b>[000]</b> Forward/Stop;	Back/Stop							
<b>[001]</b> Boost/Stop:	Forward/Back							
<b>Direction of rotation</b>								
<b>F04</b>	Direction of rotation [000]	<b>[000]</b> Forward <b>[001]</b> Backward						
<b>Volts per Hertz characteristic</b>								
<b>F05</b>	Volts per Hertz characteristic	This is where you set the start-up behaviour. At 50Hz network: <b>[001]</b> Linear <b>[002]</b> Heavy starting <b>[003]</b> Pump/Ventilator At 60Hz network: <b>[004]</b> Linear <b>[005]</b> Heavy starting <b>[006]</b> Pump/Ventilator						
 Note	<ul style="list-style-type: none"> <li>For ventilators and pumps with a great breakaway torque or moment of inertia "Linear" setting may be of an advantage.</li> <li>Parameter F25 (default value for frequency) is not automatically changed at the same time. You must set the corner frequency separately.</li> </ul>							
<b>Maximum and minimum speed</b>								
<b>F06</b>	max. rpm: [50.0]	Maximum value for excitation frequency Excitation frequency is proportional to speed. => Specification of maximum speed. Setting range available from <b>[1.0]</b> Hz to <b>[200]</b> Hz						
<b>F07</b>	Minimum speed [00.0]	Minimum value for excitation frequency Excitation frequency is proportional to speed. => Specification of minimum speed. Setting range available from <b>[1.0]</b> Hz to <b>[200]</b> Hz						

Parameter	Function [default setting]	Settings [setting range]																								
<b>Fixed speed</b>																										
<b>F08</b>	Fixed target value 1 [10.0]	This is where you can set a fixed value for excitation frequency. => Static torque Setting range available from <b>[0.0]</b> Hz to <b>[200]</b> Hz.																								
<b>Inching frequency</b>																										
<b>F09</b>	Inching-nominal value [6.0]	Fixed value for inching mode Setting range available from <b>[0.0]</b> Hz to <b>[200]</b> Hz.																								
<b>Enable local/remote mode</b>																										
<b>F10</b>	Enable [000] [001]FRU-200-25W/75W	Change between remote operation and manual operation. <b>[000]</b> Local mode via RUN/STOP key <b>[001]</b> Remote mode via terminal 3 FW (boost)																								
<b>Specified value selection local/remote</b>																										
<b>F11</b>	Specified value selection [001] [000]FRU-200-25E/75E	Default for specified value of excitation frequency <b>[000]</b> Local specified value (manual selection via control panel) <b>[001]</b> Remote specified value (via POT)																								
<b>Clock frequency</b>																										
<b>F12</b>	Clock frequency [005]	<table border="1"> <thead> <tr> <th>Parameter value</th> <th>Frequency</th> <th>Parameter value</th> <th>Frequency</th> </tr> </thead> <tbody> <tr> <td><b>[001]</b></td> <td>4kHz</td> <td><b>[006]</b></td> <td>10kHz</td> </tr> <tr> <td><b>[002]</b></td> <td>5kHz</td> <td><b>[007]</b></td> <td>12kHz</td> </tr> <tr> <td><b>[003]</b></td> <td>6kHz</td> <td><b>[008]</b></td> <td>14.4kHz</td> </tr> <tr> <td><b>[004]</b></td> <td>7.2kHz</td> <td><b>[009]</b></td> <td>15kHz</td> </tr> <tr> <td><b>[005]</b></td> <td>8kHz</td> <td><b>[010]</b></td> <td>16kHz</td> </tr> </tbody> </table>	Parameter value	Frequency	Parameter value	Frequency	<b>[001]</b>	4kHz	<b>[006]</b>	10kHz	<b>[002]</b>	5kHz	<b>[007]</b>	12kHz	<b>[003]</b>	6kHz	<b>[008]</b>	14.4kHz	<b>[004]</b>	7.2kHz	<b>[009]</b>	15kHz	<b>[005]</b>	8kHz	<b>[010]</b>	16kHz
Parameter value	Frequency	Parameter value	Frequency																							
<b>[001]</b>	4kHz	<b>[006]</b>	10kHz																							
<b>[002]</b>	5kHz	<b>[007]</b>	12kHz																							
<b>[003]</b>	6kHz	<b>[008]</b>	14.4kHz																							
<b>[004]</b>	7.2kHz	<b>[009]</b>	15kHz																							
<b>[005]</b>	8kHz	<b>[010]</b>	16kHz																							
 Note	<ul style="list-style-type: none"> <li>• Clock frequencies from 12 kHz only support operation with small load.</li> <li>• A high clock frequency reduces motor noise but causes higher losses in the frequency converter and bad rotational behaviour at a low output frequency.</li> </ul>																									

Parameter	Function [default setting]	Settings [setting range]
<b>Voltage elevation (Boost) at low frequency</b>		
F13	Boost [0.0]	<p>A boost facilitates the setting of sensible magnetization for the motor at low speed in order to achieve a higher starting torque for drives with high breakaway torque. The voltage in the lower speed range will be purposefully increased in relation to the desired volts per Hertz characteristic.</p>  <p>U: Output voltage f<sub>B</sub>: Corner frequency B: Boost</p> <p>This is adjustable within a range of <b>[0.0] %</b> to <b>[10.0] %</b> of the maximum output voltage.</p>
 Note	<ul style="list-style-type: none"> <li>The parameter Boost should only be increased to the point required to reach the necessary starting torque. Setting too high a value may cause a fault in the frequency converter due to overcurrent, or boost may fail or motor may succumb to thermal overload.</li> </ul>	
<b>Stop mode</b>		
F14	Stop mode [000]	<p><b>[000]</b> Ramp: Controlled deceleration on ramp according to set value for parameter F02)</p> <p><b>[001]</b> Coasting: Deceleration without brake effect</p>
<b>Direct current braking</b>		
F15	Braking time [0.5]	<p>Brake time indicates how long it takes before the motor is braked by means of direct current after the deceleration of the ramp</p> <p>Setting range available from <b>[0.0]s</b> to <b>[25.5]s</b>.</p>
F16	Starting frequency [1.5]	<p>Frequency at which direct current braking starts during deceleration</p> <p>Setting range available from <b>[1.0]Hz</b> to <b>[10.0]Hz</b>.</p>
F17	Braking voltage [8.0]	<p>Variable of braking voltage for direct current braking pulse</p> <p>Setting range available from <b>[0.0]%</b> to <b>[20.0]%</b>.</p>
<b>Motor rated current</b>		
F18	Motor current [100]	Setting range available from <b>[0.0]%</b> to <b>[200]%</b> .
 Note	<p>To protect the motor against overload, it is possible to set the motor current in relation to the output current of the FRU-200. The FRU-200 switches off after 1 minute at settings below 100% and when reaching 150% of the motor current set. Error message <b>OL1 – Motor Overload</b> appears. Settings of more than 100% will result in a switch-off of the FRU-200 after reaching an overload of 150%, generating error message <b>OL2 – Frequency Converter Overload</b>.</p>	

Parameter	Function [default setting]	Settings [setting range]																
<b>Multi-function inputs</b>																		
<b>F19</b>	Multi-function input1 (terminal6) [002]	These inputs are ready for operation using the following settings:  <table border="0"> <thead> <tr> <th>Parameter</th> <th>Meaning</th> </tr> </thead> <tbody> <tr> <td>[001]</td> <td>Inching mode with inching frequency from F09</td> </tr> <tr> <td>[002]*</td> <td>Fixed specified value1 with frequency from F08</td> </tr> <tr> <td>[003]</td> <td>Emergency shutdown (stop mode F14 is ignored)</td> </tr> <tr> <td>[004]</td> <td>External supervision</td> </tr> <tr> <td>[005]</td> <td>Reset – faults are reset.</td> </tr> <tr> <td>[006]*</td> <td>Fixed specified value2 with frequency from F26</td> </tr> </tbody> </table>	Parameter	Meaning	[001]	Inching mode with inching frequency from F09	[002]*	Fixed specified value1 with frequency from F08	[003]	Emergency shutdown (stop mode F14 is ignored)	[004]	External supervision	[005]	Reset – faults are reset.	[006]*	Fixed specified value2 with frequency from F26		
Parameter	Meaning																	
[001]	Inching mode with inching frequency from F09																	
[002]*	Fixed specified value1 with frequency from F08																	
[003]	Emergency shutdown (stop mode F14 is ignored)																	
[004]	External supervision																	
[005]	Reset – faults are reset.																	
[006]*	Fixed specified value2 with frequency from F26																	
<b>F20</b>	Multi-function input2 (terminal7) [005]																	
<b>*Enable command (terminal 3) must be issued for operation with fixed specified values. In addition follow the engineering logic shown below:</b>																		
	<table border="1"> <thead> <tr> <th></th> <th>Multi-function Input1</th> <th>Multi-function Input2</th> <th>Output frequency</th> </tr> </thead> <tbody> <tr> <td>Fixed target value 1</td> <td>ON</td> <td>OFF</td> <td>Value from F08</td> </tr> <tr> <td>Fixed target value 2</td> <td>OFF</td> <td>ON</td> <td>Value from F26</td> </tr> <tr> <td>Fixed target value 3</td> <td>ON</td> <td>ON</td> <td>Value from F27</td> </tr> </tbody> </table>		Multi-function Input1	Multi-function Input2	Output frequency	Fixed target value 1	ON	OFF	Value from F08	Fixed target value 2	OFF	ON	Value from F26	Fixed target value 3	ON	ON	Value from F27	
	Multi-function Input1	Multi-function Input2	Output frequency															
Fixed target value 1	ON	OFF	Value from F08															
Fixed target value 2	OFF	ON	Value from F26															
Fixed target value 3	ON	ON	Value from F27															
	Fixed target value 4	A fourth specified value can be set via analogue input terminal9 or a local specified value. This is applied if none of the multi-function inputs is turned on.																
 Note	<ul style="list-style-type: none"> <li>• <b>Emergency shut-down:</b> The frequency converter shuts down the drive according to the set ramp.</li> <li>• <b>External supervision:</b> It is possible to connect a PCT thermistor analysing unit (make contact element)</li> <li>• <b>Reset:</b> Resetting an error message via a multi-function input</li> </ul>																	
<b>Multi-function output</b>																		
<b>F21</b>	Multi-function output [003]	<table border="0"> <tbody> <tr> <td>[001]</td> <td>Message Operation</td> </tr> <tr> <td>[002]</td> <td>Message Specified Value has been reached</td> </tr> <tr> <td>[003]</td> <td>Error</td> </tr> </tbody> </table> <b>Notice:</b> Relay contact max 250VAC/1A or 30VDC/1A	[001]	Message Operation	[002]	Message Specified Value has been reached	[003]	Error										
[001]	Message Operation																	
[002]	Message Specified Value has been reached																	
[003]	Error																	
<b>Change of direction</b>																		
<b>F22</b>	Change of direction [000]	<table border="0"> <tbody> <tr> <td>[000]</td> <td>Change of direction possible</td> </tr> <tr> <td>[001]</td> <td>Change of direction blocked</td> </tr> </tbody> </table> <b>Notice:</b> Forward is the only possible direction of rotation. F04 cannot be set to [001].	[000]	Change of direction possible	[001]	Change of direction blocked												
[000]	Change of direction possible																	
[001]	Change of direction blocked																	
<b>Automatic restart</b>																		
<b>F23</b>	Automatic ON [001]	<table border="0"> <tbody> <tr> <td>[000]</td> <td>enabled</td> </tr> <tr> <td>[001]</td> <td>disabled</td> </tr> </tbody> </table>	[000]	enabled	[001]	disabled												
[000]	enabled																	
[001]	disabled																	
 Attention	<ul style="list-style-type: none"> <li>• This must not be changed as otherwise restart protection after faults would no longer be guaranteed.</li> </ul>																	
 Note	<ul style="list-style-type: none"> <li>• In case of a power failure of less than 2s, you can select this function in order to decide whether the frequency converter is supposed to restart or to move into error mode.</li> <li>• Error message LUC is issued during setting [001] and short-term power failures.</li> </ul>																	

Parameter	Function [default setting]	Settings [setting range]
<b>Number of restarting attempts</b>		
<b>F24</b>	Selecting an output [0]	When the frequency converter moves into error mode due to a pending error message, this parameter can be used to determine how many restart attempts should be made. If the fault happens on both sides, the converter will restart. Adjustment range available from <b>[0]</b> to <b>[5]</b> .
 Note	<ul style="list-style-type: none"> <li>• If F24=0, the frequency converter will not try to restart during a pending error message.</li> <li>• If the converter currently works by applying direct current braking or tries to shut down but an error occurs, restarting will not be possible.</li> </ul>	
<b>Default setting</b>		
<b>F25</b>	Default setting	Corner frequency is fixed and preset <b>[010]</b> Default setting 50Hz <b>[020]</b> Default setting 60Hz <b>Notice:</b> Parameter F25 will be automatically reset to 000 after a RESET to default settings has taken place.
 Attention	<ul style="list-style-type: none"> <li>• After all changes the parameter F23 will be set to [000], i. e. restart protection after error is no longer ensured!</li> <li>• Change parameter F23 to [001]!</li> </ul>	
<b>Fixed speeds 2 and 3</b>		
<b>F26</b>	Fixed speed 2 [20.0]	This is where you can set a fixed value for excitation frequency. => Static torque Setting range available from <b>[0.0]</b> Hz to <b>[200]</b> Hz.
<b>F27</b>	Fixed speed 3 [30.0]	This is where you can set a fixed value for excitation frequency. => Static torque Setting range available from <b>[0.0]</b> Hz to <b>[200]</b> Hz.
<b>Automatic start after connecting mains voltage</b>		
<b>F28</b>	Auto-Start [001] (program version 2.2 or later)	Auto-Start function after connecting mains voltage: <b>[000]</b> Auto-Start with enabling terminal 3 after connection of mains voltage possible <b>[001]</b> Auto-Start with enabling terminal 3 after application of mains voltage <b>not</b> possible
 Attention	<ul style="list-style-type: none"> <li>• After a power failure of more than 2s this function can be used to select whether the frequency converter with pending release at terminal 3 should restart directly. .</li> <li>• If changed, a direct start after applying the mains voltage will not be possible!</li> </ul>	

Parameter	Function [default setting]	Settings [setting range]
<b>Display parameter</b>		
<b>F28</b>	Reserve	
<b>F29</b>	CPU program version	
<b>F30</b>	Error messages	<p>This parameter is used to display and reset the last three error messages. The order of error messages is indicated by a full stop.</p> <p>x.xx Last error message</p> <p>xx.x One but last error message</p> <p>xxx. First error message</p>
 <b>Note</b>	<ul style="list-style-type: none"> <li>• To display the last three error messages, press the arrow <b>UP</b> key.</li> <li>• To reset error messages, press the arrow <b>DOWN/RESET</b> key.</li> </ul>	

## 9 Operating and error messages

### 9.1 General

FRU-200 frequency converter offer many warning and error evaluation functions. This considerably reduces the danger of damage to frequency converter, motor and related equipment under faulty conditions. The diagnosis information on the control panel's display unit often facilitates quick error location. If you detect a fault in the FRU-200 frequency converter, return the frequency converter to the supplier; we strongly advice against repairs on-site.

### 9.2 Operation messages

message	Significance	Cause
<i>SPO</i>	<b>Zero speed</b>	Specified value frequency is smaller than 1Hz, at min. speed F07 =000
<i>SP1</i>	<b>Auto-Start impossible</b>	Release/boost command at terminal 3 is enabled when mains voltage is applied but the auto-start function disabled. Check setting of parameter F28.
<i>SP2</i>	<b>Local mode Emergency stop</b>	Frequency converter is working in remote specified value mode and <b>RUN/STOP</b> key is pressed on frequency converter. You will have to reset Release/Boost, before you can restart.
<i>E.S.</i>	<b>Remote specified value Emergency stop</b>	One of the multi-function inputs F19/F20 has been configured to Emergency Stop function and this message is pending (operating mode: local mode and remote specified value)
<i>B.B.</i>	<b>External supervision</b>	One of the multi-function inputs F19/F20 has been configured to External Supervision function and this message is pending (operating mode: local mode and remote specified value)

### 9.3 Setting error)

message	Significance	Cause	Remedy
<i>LOC</i>	<b>Change of direction of rotation blocked</b>	<ol style="list-style-type: none"> <li>F22 =001 and via input REV (terminal 4), to reverse and to change direction of rotation</li> <li>F22 and F04 are simultaneously set to 001</li> </ol>	<ul style="list-style-type: none"> <li>- Set F22 to 000</li> <li>- Set F04 to 000</li> </ul>
<i>ER1</i>	<b>Error 1</b>	<ol style="list-style-type: none"> <li>Frequency converter is working in operating mode remote specified value (F11=001) and the arrow keys <b>UP</b> or <b>DOWN/RESET</b> were pressed</li> <li>An attempt was made to change CPU program version F29</li> <li>Parameter should be changed during operation</li> </ol>	<ul style="list-style-type: none"> <li>- The arrow keys are used in local mode only to increase or decrease the output frequency</li> <li>- CPU program version is non-alterable</li> <li>- Merely parameters F01, F02, F04 and F13 can be changed during operation</li> </ul>
<i>ER2</i>	<b>Error 2</b>	<ol style="list-style-type: none"> <li>Parameter error F06, F07</li> </ol>	<ul style="list-style-type: none"> <li>- F06 &gt; F07</li> </ul>

## 9.4 Error messages

### Error messages that cannot be reset

Message	Significance	Cause	Remedy
<i>CPF</i>	<b>Program error</b>	External electromagnetic effect	- Connect in parallel RC absorption circuit with interfering magnetic contact
<i>EPR</i>	<b>EEPROM error</b>	EEPROM defect	- Check and replace memory module, as required
<i>OU</i>	<b>Excess voltage in standby mode</b>	1. Supply voltage too high 2. Measuring arrangement defective	- Check network voltage - Contact supplier
<i>LU</i>	<b>Undervoltage in standby mode</b>	1. Supply voltage too low 2. Measuring arrangement defective	- Check network voltage - Contact supplier
<i>OH</i>	<b>Overload in standby mode</b>	1. Ambient temperature too high 2. Insufficient cooling 3. Measuring arrangement defective	- Improve cooling - Contact supplier

### Error messages that can be reset manually

message	Significance	Cause	Remedy
<i>OC</i>	<b>Overcurrent in standby mode</b>	Measuring arrangement defective	- Contact supplier
<i>OL1</i>	<b>Motor overload</b>	1. To much strain 2. Incorrect V/F characteristic 3. Current limit F18 set incorrectly	- Use larger motor - Select different V/F characteristic - Check current limit F18
<i>OL2</i>	<b>Frequency converter overload</b>	1. To much strain 2. Incorrect V/F characteristic	- Use larger frequency converter - Select different V/F characteristic

## Error messages that can be reset manually and via auto-reset

Message	Significance	Cause	Remedy
<i>OCS</i>	<b>Short-term start-up peak current</b>	1 Motor short at housing 2 Motor cable short at earth 3 Power transistor defective	- Check motor - Check motor cable - Contact supplier
<i>OCA</i>	<b>Overcurrent on boosting</b>	1 Boost ramp set too short 2 Incorrect V/F characteristic 3 Motor performance too high	- Set boost ramp longer - Select different V/F characteristic - Use larger frequency converter
<i>OCC</i>	<b>Overcurrent in continuous operation</b>	1 Short-term overload 2 Short-term power cut	- Check load conditions - Apply power choke
<i>OCD</i>	<b>Overcurrent during coasting</b>	Coasting ramp too short	- Set coasting ramp longer
<i>OCB</i>	<b>Overcurrent on braking</b>	<b>Direct current braking</b> 1 Braking time too long F15 2 Starting frequency too high F16 3 Braking voltage too high F17	- Check parameter settings F15, F16, F17
<i>OUC</i>	<b>Overvoltage during operating or coasting</b>	1 Coasting ramp too short 2 Moment of inertia too large 3 Excessive supply fluctuations	- Set coasting ramp longer - Use larger frequency converter - Apply power choke
<i>LUC</i>	<b>Mains voltage insufficient</b>	1 Mains voltage too low 2 Excessive supply fluctuations	- Check the power voltage - Set boost ramp longer - Use larger frequency converter - Apply power choke
<i>OHC</i>	<b>Heat sink overtemperature</b>	1 To much strain 2 Ambient temperature too high 3 Insufficient ventilation	- Check strain - Use larger frequency converter - Check ventilation

## 9.5 Further troubleshooting

Problem	Possible cause	Remedy
<b>Motor does not rotate</b>	Is mains voltage applied, is green LED lit up?	- Check mains voltage - Connect and then disconnect mains voltage
	Is voltage applied to terminals T1, T2 and T3?	- Connect and then disconnect mains voltage - Check wiring
	Check whether incorrect parameter settings were selected?	- Where necessary, reset to default setting
	Motor jammed? Is remote specified value applied to analogue input?	- Turn off device and check mechanics - Check wiring of terminal 9 MVI
<b>Motor rotating in wrong direction</b>	Have terminals T1, T2, T3 been mixed up?	- Check wiring
	Are inputs FW and RE wired correctly?	- Check wiring
<b>Motor is rotating at fixed speed</b>	Is the wiring of analogue input terminal 9 correct?	- Check wiring
	Was the right operating mode selected?	- Check parameter setting
	Is the load too large?	- Check parameter setting
<b>Motor speed too high or low</b>	Are the motor parameters (number of pins, voltage) correct?	- Reduce load
	Was the right gear transmission selected?	- Check motor dimensioning
	Was the correct maximum speed selected?	- Take gear transmission into account
	Voltage dip at motor during maximum speed?	- Reduce maximum speed
<b>Reduce strong speed Fluctuations</b>	Is the load too large?	- Load fluctuations
	Are the load fluctuations too great?	- Increase motor and frequency converter capacity
	Is the mains voltage constant?	- Install power choke up-stream of frequency converter

---

## 10 Service

### 10.1 Regular maintenance

FRU-200 frequency converters are to a great extent maintenance-free. Despite this, the following tests should be carried out at regular intervals:

1.) Ventilation:

- Is the ventilator noise audible? (0.37kW and 0.75kW only)
- Is the cooling air able to circulate unhampered around the device?

2.) Fixings, connections:

- Are the mounting fittings of the FRU-200 firmly tightened?
- Are all connections properly clamped?

### 10.2 Repair

Users will not be able to repair the FRU-200 frequency converter themselves. In case of an error, we recommend to return the defective device for repairs.



- Disconnect the FRU-200 frequency converter completely from the power supply before starting with disassembling.
- Take discharge time of intermediate circuit capacitors (approx. 3 min) into account. Non-compliance may result in fatal electric shock if device is touched.

### 10.3 Returns

If an error requires the return of a FRU-200 frequency converter, we recommend following the procedure below:

- Contact your supplier and have the following information ready for your phone call:
  - Type of FRU-200 frequency converter
  - Series no.
- Your supplier will be happy to explain the arrangements with respect to an exchange and the necessary formalities involved.
- Return your device in environmentally friendly, reusable packaging suited for this kind of transport.
- Do not forget to enclose a coherent error description with your device. This reduces repair times and lowers repairs costs.